

---

---

# MITSUBISHI SEWING MACHINE PARTS CATALOG

Model.....DU-100~128

## INDEX

1. 本体部分.....	Arm bed.....	P00- 1
2. 上糸調節器部分.....	Upper thread tension regulator mechanism.....	P00- 5
3. 上部上下送り機構部分.....	Walking foot motion mechanism.....	P00- 7
4. 上軸と押えばね機構部分.....	Upper shaft & pressure spring mechanism.....	P00- 9
5. タイミングベルト車と安全クラッチ機構部分.....	Timing belt wheel & safety-clutch mechanism.....	P00-11
6. 針棒と天びん機構部分.....	Needle bar & thread take-up lever mechanism.....	P00-13
7. 針棒揺動機構部分.....	Needle bar rocking motion mechanism.....	P00-15
8. かま機構部分.....	Rotating hook mechanism.....	P00-17
9. 下軸と縫い目加減機構部分.....	Lower shaft & stitch regulator mechanism.....	P00-21
10. 送り機構部分.....	Feed rocking motion mechanism.....	P00-23
11. 返し縫い機構部分.....	Reverse sewing motion mechanism.....	P00-25
12. 給油機構部分.....	Oil lubrication mechanism.....	P00-27
13. ゲージ部品の組合せ.....	Gauge parts & its complement.....	P00-31
14. 付 属 品.....	Accessories.....	P00-35

From the library of: Diamond Needle Corp



MITSUBISHI ELECTRIC CORPORATION

---

---

197711

DU-100形 本体部分 ARM BED

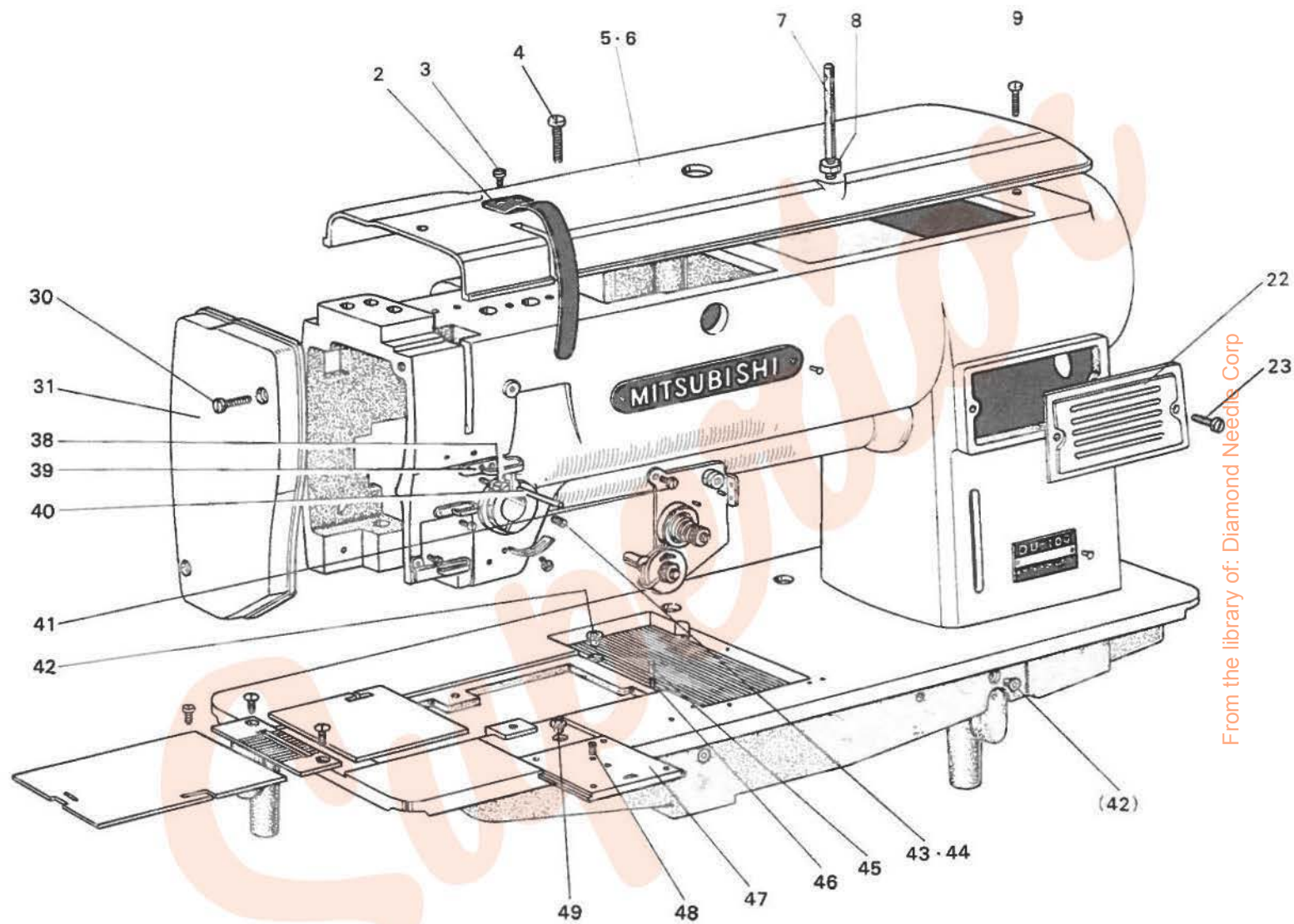

From the library of: Diamond Needle Corp



DU-100形 本体部分  
ARM BED

Fig. No.	サービス部品コード Part No.	資材コード Code No.	部 品 名	Name of Part	個 / 台 Amt req												備 考 Remarks					
					DU 100	DU 110	DU 120	DU 105	DU 115	DU 125	DU 103	DU 113	DU 123	DU 108	DU 118	DU 128		DU 102	DU 112	DU 107	DU 117	DU 127
2	MP 03B0 584	W324519	天ビンカバー	Thread take-up cover									0	0	0	0	0	0				
	MN 10A0 584	W479316	天ビンカバー(新)	Thread take-up cover	0	0	0	0	0	0	0	0	0	0	0	0	0	0	0			
3	M9 0916 003	W500157	丸平ネジ 9/64(40)×6.5	Screw(for Fig.2)									2	2	2	2	2	2				
	M9 0935 002	W500294	平ネジ 11/64(40)×8(新)	Screw	2	2	2	2	2	2	2	2	2	2	2	2	2	2				
4	M9 0918 002	W500262	平ネジ 9/64(40)×23	Screw(for Fig.5,6)	0	0	0	0	0	0	0	0	1	0	0	1	0	0	1	0	0	0
5	MP 00B1 600	W220647H01	トップカバー	Armtop cover	0	0	0	0	0	0	0	0										
	MP 00B0 600	W220647H02	トップカバー(新)	Arm top cover	0	0	0	0	0	0	0	0										
6	MP 03B0 600	W220648	トップカバー	Arm top cover									0	0	0	0	0	0				
7	MN 10A2 181	W445861H02	糸カケ(トップカバー)	Arm top cover thread guide	0	0	0	0	0	0	0	0	0	0	0	0	0	0	0	0	0	0
8	M9 1202 045	W500001	ナット 3 16(28)×4	Arm top cover thread guide nut	0	0	0	0	0	0	0	0	0	0	0	0	0	0	0	0	0	0
9	M9 0915 002	W500261	平ネジ 9/64(40)×14	Screw(for Fig.5,6)	0	0	0	0	0	0	0	0	0	0	0	0	0	0	0	0	0	0
22	MN 10A0 800	W461026	前蓋	Arm side cover	0	0	0	0	0	0	0	0	0	0	0	0	0	0	0	0	0	0
23	M9 1101 004	W466810	ブラマイネジ 11/64(40)×8	Arm side cover set screw	2	2	2	2	2	2	2	2	2	2	2	2	2	2	2	2	2	2
30	M9 0901 001	W500588	頭ナシ止メネジ 9/64(40)×3.7	Face plate set pin screw	0	0	0	0	0	0	0	0	0	0	0	0	0	0	0	0	0	0
	M9 1102 004	W467880	ブラマイネジ 11/64(40)×10(新)	Face plate set pin screw	2	2	2	2	2	2	2	2										
31	MN 12B0 830	W220608	面 板 (旧)	Face plate	0	0	0	0	0	0	0	0										
	MN 10A1 830	W338247	面 板 (新)	Face plate	0	0	0	0	0	0	0	0										
32	MP 03B0 830	W220623	面 板 (旧)	Face plate									0	0	0	0	0	0	0	0	0	0
33	M9 0504 063	W445860	面 板 支 工 軸 (旧面版用)	Face plate set pin	0	0	0	0	0	0	0	0	0	0	0	0	0	0	0	0	0	0
34	MP 00B0 805	W445862	面 板 止 メ バ ネ (旧面版用)	Face plate set spring	0	0	0	0	0	0	0	0	0	0	0	0	0	0	0	0	0	0
35	M9 0503 063	W500989	ピ ン 5φ×7(旧面版用)	Face plate set pin	0	0	0	0	0	0	0	0	0	0	0	0	0	0	0	0	0	0
36	MN 10A0 476	W445874	座 板<スペース>(旧面版用)	Face plate set pin washer	0	0	0	0	0	0	0	0	0	0	0	0	0	0	0	0	0	0
37	MN 10A0 131	W445863	油 除 け 板<油受け>(旧面版用)	Oil plate	0	0	0	0	0	0	0	0	0	0	0	0	0	0	0	0	0	0
38	M9 1201 011	W500993	丸 皿 ネジ 3 16(28)×11	Arm thread guide(upper)set screw	2	2	2	2	2	2	2	2	2	2	2	2	2	2	2	2	2	2
39	MN 10A0 181	W445857	糸カケ(アーム上)	Arm thread guide(upper)	0	0	0	0	0	0	0	0	0	0	0	0	0	0	0	0	0	0
40	M9 0402 060	W462904	糸ユルメピン(大) 4φ×57	Tension releasing pin(large)	0	0	0	0	0	0	0	0	0	0	0	0	0	0	0	0	0	0
41	M9 1110 002	W500294	平ネジ 11/64(40)×8	Tension regulator bracket screw	0	0	0	0	0	0	0	0	0	0	0	0	0	0	0	0	0	0
42	MN 10A4 742	W462905	フ タ	CaP	3	3	3	3	3	3	3	3	3	3	3	3	3	3	3	3	3	3
43	M9 1513 001	B 509060	頭ナシ止メネジ 15/64(28)×11	Tension stud screw	0	0	0	0	0	0	0	0	0	0	0	0	0	0	0	0	0	0
44	M9 1111 001	B 503852	頭ナシ止メネジ 11/64(40)×10	Tension stud screw	0	0	0	0	0	0	0	0	0	0	0	0	0	0	0	0	0	0
45	M9 0401 060	W501034	ピ ン 4φ×10	Pin	0	0	0	0	0	0	0	0	0	0	0	0	0	0	0	0	0	0
46	MN 10A0 572	W501035	バ ネ	Spring	0	0	0	0	0	0	0	0	0	0	0	0	0	0	0	0	0	0
47	MP 20B0 472	W462906	スベリ板(前)	Slide plate(front)									0	0	0	0	0	0	0	0	0	0
48	M9 1301 001	W501005	頭ナシ止メネジ 13/64(32)×4.8	Slide plate(front)set screw									0	0	0	0	0	0	0	0	0	0
49	MG 10B0 138	B 419023	油 ツ ボ(玉入)	Oil plug(in ball)	0	0	0	0	0	0	0	0	0	0	0	0	0	0	0	0	0	0

DU-100形 本体部分 ARM BED

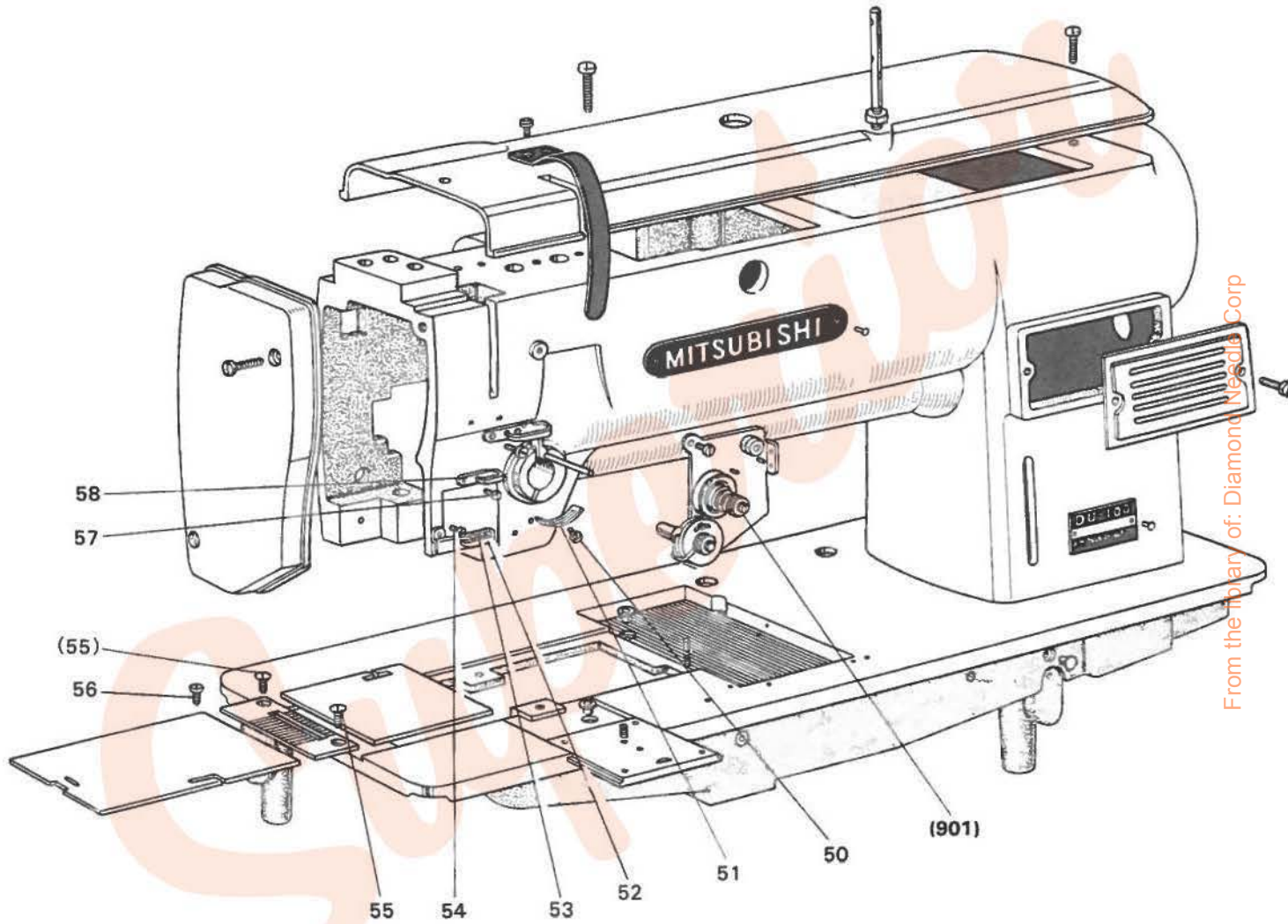

From the library of: Diamond Mesclia Corp



DU-100形 本体部分  
ARM BED

Fig. No.	サービス部品コード Part No.	資材コード Code No.	部 品 名	Name of Part	個 / 台 Amt req													備 考 Remarks							
					DU 100	DU 110	DU 120	DU 105	DU 115	DU 125	DU 103	DU 113	DU 123	DU 108	DU 118	DU 128	DU 102		DU 112	DU 122	DU 107	DU 117	DU 127		
50	M9 0907 002	W500076	平 ネ ジ 9/64(40)×5	Thread take-up spring stoper set screw	1	1	1	1	1	1	1	1	1	1	1	1	1	1	1	1	1	1	1		
51	MN 10A0 477	W445942	糸トリバネストッパー	Thread take-up spring stoper	1	1	1	1	1	1	1	1	1	1	1	1	1	1	1	1	1	1	1		
52	MP 00B0 181	W456528	糸カケ(アーム下)	Arm thread guide(lower)	1	1	1	1	1	1	1	1	1	1	1	1	1	1	1	1	1	1	1		
53	MP 00B0 740	W502486	フェルト	Felt(for Fig.52)	1	1	1	1	1	1	1	1	1	1	1	1	1	1	1	1	1	1	1		
54	M9 0920 002	W501523	平 ネ ジ 9/64(40)×6.5	Arm thread guide(lower)set screw	1	1	1	1	1	1	1	1	1	1	1	1	1	1	1	1	1	1	1		
55	M9 1106 011	W502948	丸 皿 ネ ジ 11/64(40)×8	Needle plate set screw	2	2	1	2	2	1	2	2	1	2	2	1	2	2	1	2	2	1	2	2	
56	M9 0951 003	W501004	丸 平 ネ ジ 9/64(36)×6.5	Slide plate set screw		1			1		1		1		1		1		1		1		1		
57	M9 0904 011	W500147	丸 皿 ネ ジ 9/64(40)×6.5	Arm thread guide(center)set screw		1			1		1		1		1		1		1		1		1		
58	MN 10A2 181	W445858	糸カケ(アーム中)	Arm thread guide(center)	1	1	1	1	1	1	1	1	1	1	1	1	1	1	1	1	1	1	1		

From the library of: Diamond Needle Corp

DUクラスの上糸調節器部分  
 UPPER THREAD TENSION REGULATOR MECHANISM

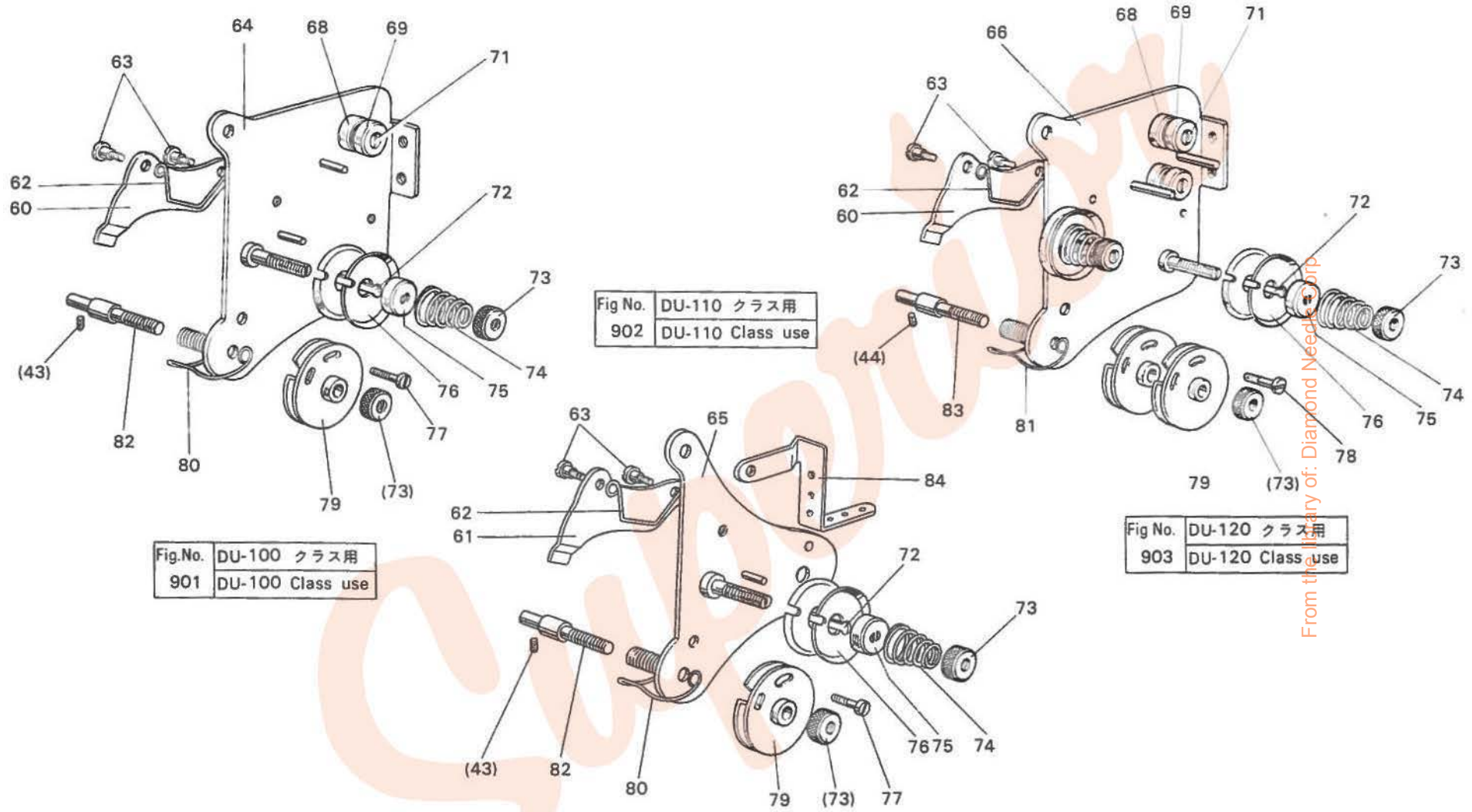

Fig.No.	DU-100 クラス用
901	DU-100 Class use

Fig No.	DU-110 クラス用
902	DU-110 Class use

Fig No.	DU-120 クラス用
903	DU-120 Class use

From the Library of: Diamond Needle Corp



DUクラスの上糸調節器部分

UPPER THREAD TENSION REGULATOR MECHANISM

Fig No.	サービス部品コード Part No.	資材コード Code No.	部 品 名	Name of Part	個 / 台 Amt. req											備 考 Remarks							
					DU-100	DU-110	DU-120	DU-105	DU-115	DU-125	DU-103	DU-113	DU-123	DU-108	DU-118		DU-128	DU-102	DU-112	DU-122	DU-107	DU-117	DU-127
901	MP 00E0 210	W225155	上糸調節器組	Thread tension regulator complete		1																	
902	MP 10E0 210	W456525	上糸調節器組	Thread tension regulator complete	1																		
903	MP 20E0 210	W227438	上糸調節器組	Thread tension regulator complete		1																	
60		W450020	糸ユルメ板上糸調節器ニ含ム	Tension releasing plate	1	1																	
61		W445931	糸ユルメ板上糸調節器ニ含ム	Tension releasing plate		1																	
62	MN 10A0 851	W502148	戻シバネ上糸調節器ニ含ム	Tension releasing spring	1	1	1	1	1	1	1	1	1	1	1	1	1	1	1	1	1	1	
63	M9 0902 015	W501026	段付平ネジ 9/64(40)上糸調節器ニ含ム	Tension releasing spring set screw	2	2	2	2	2	2	2	2	2	2	2	2	2	2	2	2	2	2	
64		W462908	糸加減座セット上糸調節器ニ含ム	Tension regulator bracket set	1																		
65		W462909	糸加減座セット上糸調節器ニ含ム	Tension regulator bracket set		1																	
66		W462823	糸加減座セット上糸調節器ニ含ム	Tension regulator bracket set			1																
68	MN 10A0 155	W502213	糸案内台上糸調節器ニ含ム	Thread guide bracket	1	2	1	2	1	2	1	2	1	2	1	2	1	2	1	2	1	2	
69	MN 10A1 555	W502212	糸案内皿(調子口)上糸調節器ニ含ム	Thread guide disc	1	2	1	2	1	2	1	2	1	2	1	2	1	2	1	2	1	2	
71	M9 0930 016	W462822	段付丸平ネジ 9/64(40)上糸調節器ニ含ム	Thread tension releasing screw	1	2	1	2	1	2	1	2	1	2	1	2	1	2	1	2	1	2	
72	M9 0202 060	W502064	糸ユルメピン(小) 2φ×12上糸調節器ニ含ム	Tension releasing pin(small)	1	1	2	1	1	2	1	1	2	1	1	2	1	1	2	1	1	2	
73	M9 1603 046	W502940	調子ナット 1/4(40)×4.5上糸調節器ニ含ム	Tension releasing thumb nut	2	2	3	2	2	3	2	2	3	2	2	3	2	2	3	2	2	3	
74	MF 23C0 245	W461786	糸調子バネ上糸調節器ニ含ム	Tension spring	1	1	2	1	1	2	1	1	2	1	1	2	1	1	2	1	1	2	
75	MN 10A0 556	W445934	皿オサエ上糸調節器ニ含ム	Tension regulator presser disc	1	1	2	1	1	2	1	1	2	1	1	2	1	1	2	1	1	2	
76	MN 10A0 555	W445933	調子皿上糸調節器ニ含ム	Tension regulator disc	2	2	4	2	2	4	2	2	4	2	2	4	2	2	4	2	2	4	2
77	M9 0602 003	W501057	丸平ネジ 3/32(56)×6上糸調節器ニ含ム	Thread controller disc screw	1	1	1	1	1	1	1	1	1	1	1	1	1	1	1	1	1	1	
78	M9 0603 003	W502062	丸平ネジ 3/32(56)×12上糸調節器ニ含ム	Thread controller disc screw			1			1			1			1			1			1	
79	MN 10E0 175	W462825	糸案内車セット上糸調節器ニ含ム	Thread controller disc set	1	1	2	1	1	2	1	1	2	1	1	2	1	1	2	1	1	2	
80	MP 00B0 187	W456524	糸取りバネ上糸調節器ニ含ム	Thread take-up spring	1	1		1	1		1	1		1	1		1	1		1	1		
81	MP 20B0 187	W462907	糸取りバネ上糸調節器ニ含ム	Thread take-up spring		1		1		1		1		1		1		1		1		1	
82	MP 10B0 554	W445935	ミゾ付キ軸上糸調節器ニ含ム	Tension stud	1	1		1	1		1	1		1	1		1	1		1	1		
83	MN 10A0 554	W450011	調子棒上糸調節器ニ含ム	Tension stud		1		1		1		1		1		1		1		1		1	
84		W445856	六ッ目糸カケ上糸調節器ニ含ム	6-hole thread guide	1			1			1			1			1			1			

From the library of Diamond 6550

DU-100形 上部上下送り機構部分  
 WALKING FOOT MOTION MECHANISM

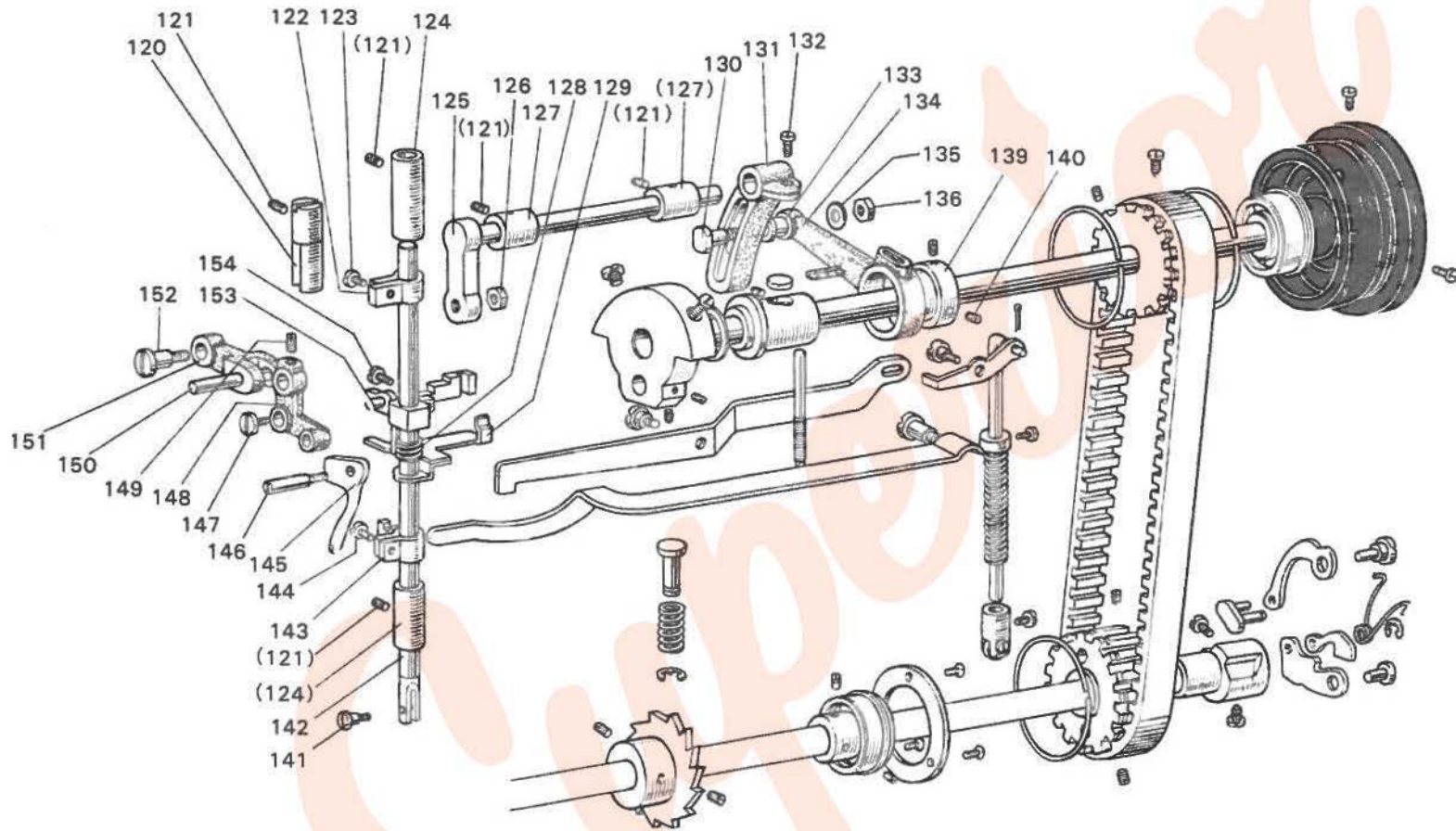

From the library of: Diamond Needle Corp



DU-100形 上部上下送り機構部分  
WALKING FOOT MOTION MECHANISM

Fig. No.	サービス部品コード Part No.	資材コード Code No.	部 品 名	Name of Part	個 / 台 Amt req													備 考 Remarks						
					DU-100	DU-110	DU-120	DU-105	DU-115	DU-125	DU-103	DU-113	DU-123	DU-108	DU-118	DU-128	DU-102		DU-112	DU-122	DU-107	DU-117	DU-127	
120	MN 10A0 263	W445918	押エ棒案内	Presser bar guide	1	1	1	1	1	1	1	1	1	1	1	1	1	1	1	1	1	1	1	
121	M9 1653 001	W500478	頭ナシ止メネジ 1/4(24)×8	Presser bar guide set screw	1	1	1	1	1	1	1	1	1	1	1	1	1	1	1	1	1	1	1	
122	MN 10A0 265	W445920	押エ棒ダキ	Presser bar holder	1	1	1	1	1	1	1	1	1	1	1	1	1	1	1	1	1	1	1	
123	M9 0903 003	B 509268	丸平ネジ 9/64(40)×10	Presser bar holder set screw	1	1	1	1	1	1	1	1	1	1	1	1	1	1	1	1	1	1	1	
124	MN 10A0 267	W445929	押エ棒メタル	Presser bar bushing	2	2	2	2	2	2	2	2	2	2	2	2	2	2	2	2	2	2	2	
125	MP 00B0 268	W461762	押エ上下軸	Feed lifting rock shaft	1	1	1	1	1	1	1	1	1	1	1	1	1	1	1	1	1	1	1	
126	M9 1802 045	B 508961	ナット 9/64(28)×3.5	Feed lifting rock shaft nut	1	1	1	1	1	1	1	1	1	1	1	1	1	1	1	1	1	1	1	
127	MG 10B0 833	W502463	メタル	Feed lifting rock shaft bushing	2	2	2	2	2	2	2	2	2	2	2	2	2	2	2	2	2	2	2	
128	MP 00B0 572	W502465	ツルマキバネ	Presser bar spring	1	1	1	1	1	1	1	1	1	1	1	1	1	1	1	1	1	1	1	
129	MP 00B0 221	W322744	上糸ユルメ板	Upper thread releasing plate	1	1	1	1	1	1	1	1	1	1	1	1	1	1	1	1	1	1	1	
130	MG 10B0 325	W502416	角 駒	Square block	1	1	1	1	1	1	1	1	1	1	1	1	1	1	1	1	1	1	1	
131	MP 00B0 462	W453576	上部上下送り腕(組)	Feed lifting rock shaft crank complete	1	1	1	1	1	1	1	1	1	1	1	1	1	1	1	1	1	1	1	
132	M9 1603 003	W501009	丸平ネジ 1/4(24)×16	Feed lifting rock shaft crank set screw	1	1	1	1	1	1	1	1	1	1	1	1	1	1	1	1	1	1	1	
133	MG 10B0 750	W462911	ブッシュ	Feed lifting rock shaft bushing	1	1	1	1	1	1	1	1	1	1	1	1	1	1	1	1	1	1	1	
134	MG 10B0 384	W453577	クランクロッド	Crank connecting rod	1	1	1	1	1	1	1	1	1	1	1	1	1	1	1	1	1	1	1	
135	M9 0607 050	W462759	座 金 M6	Crank connecting rod washer	1	1	1	1	1	1	1	1	1	1	1	1	1	1	1	1	1	1	1	
136	M9 1601 045	W501989	ナット 1/4(24)×3.5	Crank connecting rod nut	1	1	1	1	1	1	1	1	1	1	1	1	1	1	1	1	1	1	1	
139	MP 00B0 760	W462912	偏心輪(上軸用)	Eccentric(for arm shaft)	1	1	1	1	1	1	1	1	1	1	1	1	1	1	1	1	1	1	1	
140	M9 1606 001	B 504016	頭ナシ止メネジ 1/4(40)×7	Eccentric(for arm shaft)set screw	2	2	2	2	2	2	2	2	2	2	2	2	2	2	2	2	2	2	2	
141	M9 0851 015	W501007	段付平ネジ 1/8(44)×9	Presser foot set screw	1	1	1	1	1	1	1	1	1	1	1	1	1	1	1	1	1	1	1	
142	MN 10A0 262	W445919	押エ棒	Presser bar	1	1	1	1	1	1	1	1	1	1	1	1	1	1	1	1	1	1	1	
143	MN 10A0 702	W445921	バネ受け	Presser bar spring bracket	1	1	1	1	1	1	1	1	1	1	1	1	1	1	1	1	1	1	1	
144	M9 0905 002	W500470	平ネジ 9/64(40)×8.5	Presser bar spring bracket set screw	1	1	1	1	1	1	1	1	1	1	1	1	1	1	1	1	1	1	1	
145	MN 10A0 252	W459307	押エ上ゲ	Presser bar lifter	1	1	1	1	1	1	1	1	1	1	1	1	1	1	1	1	1	1	1	
146	M9 1201 033	W501024	ピンネジ 3/16(28)×24.5	Presser bar lifter screwed pin	1	1	1	1	1	1	1	1	1	1	1	1	1	1	1	1	1	1	1	
147	M9 1151 003	W502454	丸平ネジ 11/64(32)×6	Bell crank screw	1	1	1	1	1	1	1	1	1	1	1	1	1	1	1	1	1	1	1	
148	MP 00B0 763	W322716	ベルクランク	Bell crank	1	1	1	1	1	1	1	1	1	1	1	1	1	1	1	1	1	1	1	
149	M9 1202 001	W500151	頭ナシ止メネジ 3/16(28)×6	Bell crank set screw	1	1	1	1	1	1	1	1	1	1	1	1	1	1	1	1	1	1	1	
150	M9 0602 060	W462916	ピン 6.35φ×17.6	Upper feed lifting connecting pin	1	1	1	1	1	1	1	1	1	1	1	1	1	1	1	1	1	1	1	
151	MP 00B0 910	W502414	リンク	Upper feed lifting connecting link	1	1	1	1	1	1	1	1	1	1	1	1	1	1	1	1	1	1	1	
152	M9 1805 015	W502398	段付平ネジ 9/32(28)×23.5	Upper feed lifting connecting link screw	1	1	1	1	1	1	1	1	1	1	1	1	1	1	1	1	1	1	1	
153	MP 00B0 764	W322717	ベルクランク土台	Bell crank bracket	1	1	1	1	1	1	1	1	1	1	1	1	1	1	1	1	1	1	1	
154	M9 1113 002	W500182	平ネジ 11/64(40)×15	Bell crank bracket set screw	1	1	1	1	1	1	1	1	1	1	1	1	1	1	1	1	1	1	1	

DU-100形 上軸と押えばね機構部分  
 UPPER SHAFT & PRESSURE SPRING MECHANISM

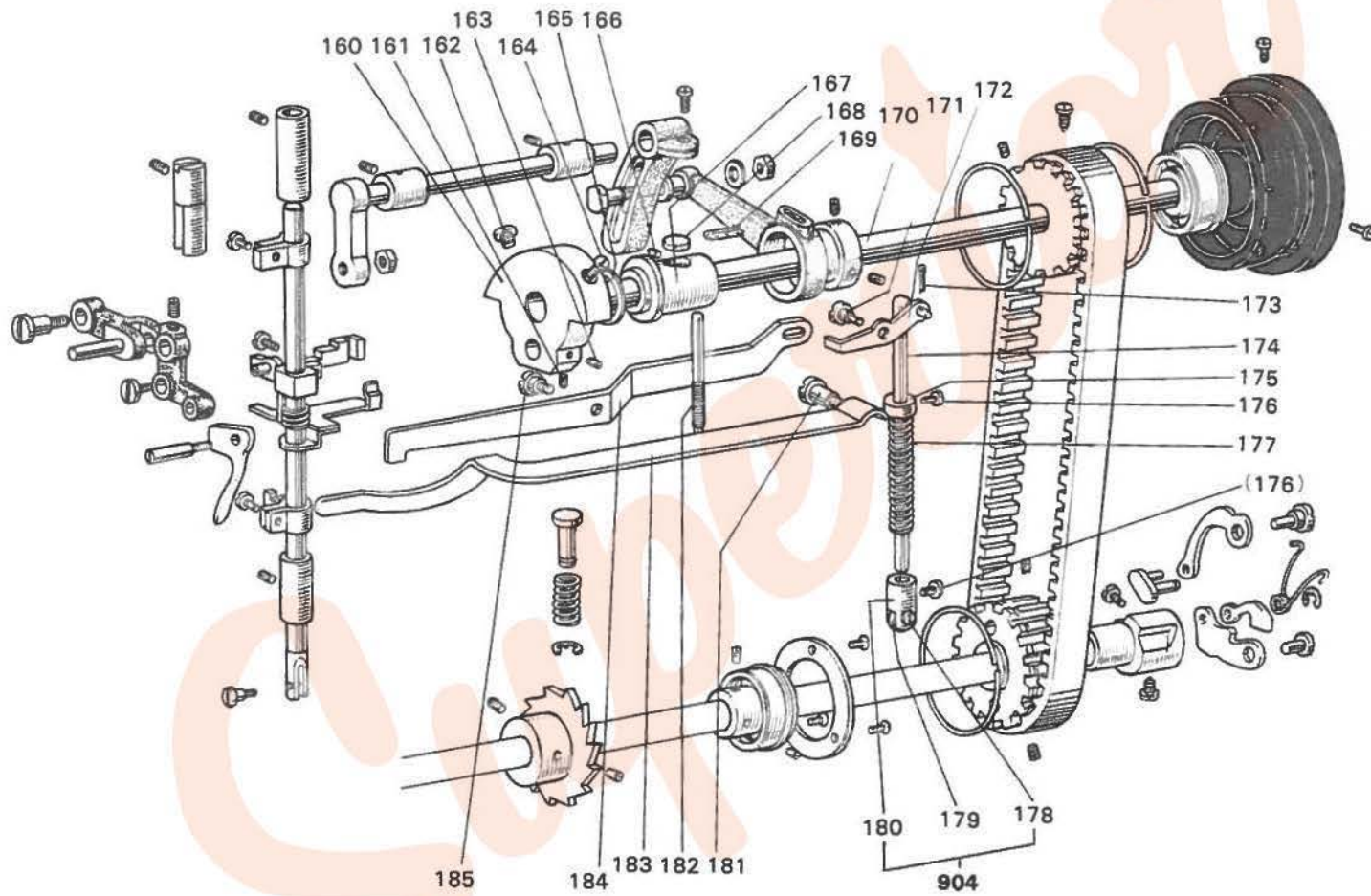

From the library of: Diamond Needle Corp



DU-100形 上軸と押えばね機構部分

UPPER SHAFT & PRESSURE SPRING MECHANISM

Fig No.	サービス部品コード Part No.	資材コード Code No.	部 品 名	Name of Part	個 / 台 Amt req														備 考 Remarks		
					DU-100	DU-110	DU-120	DU-105	DU-115	DU-125	DU-103	DU-113	DU-123	DU-108	DU-118	DU-128	DU-102	DU-112		DU-122	DU-107
160	MN 10A0 383	W445865	ク ラ ン ク	Needle bar crank	1	1	1	1	1												
	MN 12B0 383	W462915	ク ラ ン ク	Needle bar crank										1	1	1	1				
161	M9 1502 001	B 509349	頭ナシ止メネジ 15/64(28)×3.5	Needle bar crank screw	1	1	1	1	1	1	1	1	1	1	1	1	1	1	1	1	
162	M9 1801 002	W500306	平 ネ ジ 9/32(28)×13	Needle bar crank set screw	1	1	1	1	1	1	1	1	1	1	1	1	1	1	1	1	
163	M9 1508 001	B 509088	頭ナシ止メネジ 15/64(28)×8	Needle bar crank screw	1	1	1	1	1	1	1	1	1	1	1	1	1	1	1	1	
164	M9 1802 006	B 503851	棒先平ネジ 9/32(28)×14	Needle bar crank set screw	1	1	1	1	1	1	1	1	1	1	1	1	1	1	1	1	
165	MN 10A0 482	W445867	リ ン グ<スリーブ>	Needle bar crank ring	1	1	1	1	1	1	1	1	1	1	1	1	1	1	1	1	
166	M9 1654 001	W501017	頭ナシ止メネジ 1/4(24)×13.8	Arm shaft bushing(left)set screw	1	1	1	1	1	1	1	1	1	1	1	1	1	1	1	1	
167	MP 00B0 232	W462913	上軸メタル左	Arm shaft bushing(left)	1	1	1	1	1	1	1	1	1	1	1	1	1	1	1	1	
168	MN 10A2 740	W501204	フ ェ ル ト	Arm shaft bushing(left)felt	1	1	1	1	1	1	1	1	1	1	1	1	1	1	1	1	
169		W462914	毛 糸	Wool wick	1	1	1	1	1	1	1	1	1	1	1	1	1	1	1	1	
170	MN 10A0 230	W319981	上 軸	Arm shaft	1	1	1	1	1	1	1	1	1	1	1	1	1	1	1	1	
171	M9 1601 016	W501020	段付丸平ネジ 1/4(24)×14	Knee lifter lifting lever(2)hinge screw	1	1	1	1	1	1	1	1	1	1	1	1	1	1	1	1	
172	MN 10A1 725	W445923	ヒザ上ゲテコ (2)	Knee lifter lifting lever(2)	1	1	1	1	1	1	1	1	1	1	1	1	1	1	1	1	
173	M9 0101 062	W500245	割 リ ビ ン	Knee lifter lifting pin	1	1	1	1	1	1	1	1	1	1	1	1	1	1	1	1	
174	MN 10A0 511	W319994	突キ上ゲ棒	Lifting connecting rod	1	1	1	1	1	1	1	1	1	1	1	1	1	1	1	1	
175	MN 10A0 352	W445924	カ ラ ー	Lifting connecting rod collar	1	1	1	1	1	1	1	1	1	1	1	1	1	1	1	1	
176	M9 1107 002	W500092	平 ネ ジ 11/64(40)×5.5	Lifting connecting rod collar set screw	2	2	2	2	2	2	2	2	2	2	2	2	2	2	2	2	
177	MP 00B0 259	W448814	押 エ バ ネ	Presser spring	1	1	1	1	1	1	1	1	1	1	1	1	1	1	1	1	
904	MN 10E0 970	W462918	ロ ー ラ ー 組	Roller complete	1	1	1	1	1	1	1	1	1	1	1	1	1	1	1	1	
178	M9 0901 016	W501022	段付丸平ネジ 9/64(40)×11	Roller bracket set screw	1	1	1	1	1	1	1	1	1	1	1	1	1	1	1	1	
179	MN 10A0 972	W445940	ロ ー ラ ー Fig.No.904ニ含ム	Roller	1	1	1	1	1	1	1	1	1	1	1	1	1	1	1	1	
180	MN 10A0 970	W445925	ロ ー ラ ー ダ キ Fig.No.904ニ含ム	Roller bracket	1	1	1	1	1	1	1	1	1	1	1	1	1	1	1	1	
181	M9 1602 016	W501006	段付丸平ネジ 1/4(24)×29	Presser lever hinge screw	1	1	1	1	1	1	1	1	1	1	1	1	1	1	1	1	
182	M9 1601 033	W445917	ビ ン ネ ジ 1/4(40)×78	Presser adjustable screw	1	1	1	1	1	1	1	1	1	1	1	1	1	1	1	1	
183	MN 10A0 258	W319992	押 エ 板 バ ネ	Presser lever spring	1	1	1	1	1	1	1	1	1	1	1	1	1	1	1	1	
184	MP 00B0 725	W453590	ヒザ上ゲテコ (1)	Knee lifter lifting lever(1)	1	1	1	1	1	1	1	1	1	1	1	1	1	1	1	1	
185	M9 1601 016	W501020	段付丸平ネジ 1/4(24)×14	Knee lifter lifting lever(1)hinge screw	1	1	1	1	1	1	1	1	1	1	1	1	1	1	1	1	

DU-100形 タイミングベルト車と安全クラッチ機構部分  
 TIMING BELT WHEEL & SAFETY-CLUTCH MECHANISM

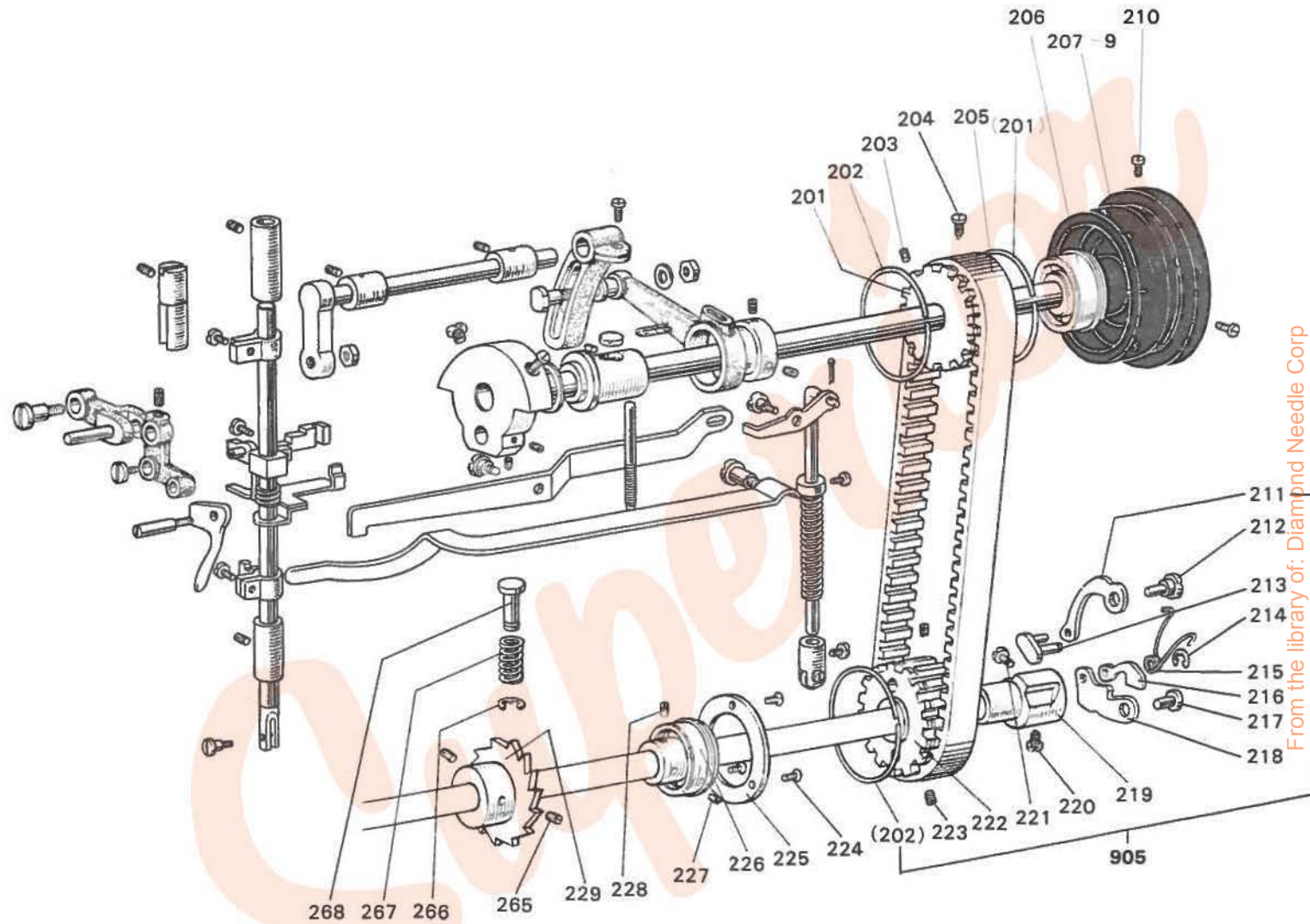

From the library of: Diamond Needle Corp



DU-100形 タイミングベルト車と安全クラッチ機構部分

TIMING BELT WHEEL & SAFETY-CLUTCH MECHANISM

Fig. No.	サービス部品コード Part No.	資材コード Code No.	部 品 名	Name of Part	個 / 台 Amt req													備 考 Remarks						
					DU-100	DU-110	DU-120	DU-105	DU-115	DU-125	DU-103	DU-113	DU-123	DU-108	DU-118	DU-128	DU-102		DU-112	DU-122	DU-107	DU-117	DU-127	
201	MN 10A0 767	W447043	ベルト車(上)(組)	Belt pulley(upper)complete	1	1	1	1	1	1	1	1	1	1	1	1	1	1	1	1	1	1	1	
202	MN 10A1 851	B 411094	バ ネ 輪	Spring flange	3	3	3	3	3	3	3	3	3	3	3	3	3	3	3	3	3	3	3	
203	M9 1511 001	W500706	頭ナシ止メネジ 15/64(28)×9.5	Belt pulley screw	1	1	1	1	1	1	1	1	1	1	1	1	1	1	1	1	1	1	1	
204	M9 1501 007	B 509256	棒先丸平ネジ 15/64(28)×14.5	Belt pulley set screw	1	1	1	1	1	1	1	1	1	1	1	1	1	1	1	1	1	1	1	
205	MP 00B0 523	W326218	タイミングベルト	Connection belt	1	1	1	1	1	1	1	1	1	1	1	1	1	1	1	1	1	1	1	
206		W445869	玉軸受(上軸用) ハズミ車組ニ含ム	Ball bearing(arm shaft)	1	1	1	1	1	1	1	1	1	1	1	1	1	1	1	1	1	1	1	
207	MN 10E0 682	W454814	ハズミ車(組)	Balance wheel	1	1	1	1	1	1	1	1	1	1	1	1	1	1	1	1	1	1	1	
208	MP 03E0 682	W464048	ハズミ車(組)	Balance wheel																				
209	MP 08E0 682	W465614	ハズミ車(組)	Balance wheel																				
210	M9 1502 002	W500509	平 ネ ジ 15/64(28)×12	Balance wheel screw	2	2	2	2	2	2	2	2	2	2	2	2	2	2	2	2	2	2	2	
905	MP 00E0 768	W324510	ベルト車下(組)	Belt Pulley(lower)complete	1	1	1	1	1	1	1	1	1	1	1	1	1	1	1	1	1	1	1	
211	MP 00B0 871	W458198	弓形バネ板 Fig.No.905ニ含ム	Safety clutch spring plate	1	1	1	1	1	1	1	1	1	1	1	1	1	1	1	1	1	1	1	
212	M9 0605 063	W502777	段付偏心ピン 6φ×14.5	Safety clutch spring plate pin	1	1	1	1	1	1	1	1	1	1	1	1	1	1	1	1	1	1	1	
213	MP 00B1 910	W502775	リ ン ク Fig.No.905ニ含ム	Safety clutch spring plate link	1	1	1	1	1	1	1	1	1	1	1	1	1	1	1	1	1	1	1	
214	M9 0502 065	W462917	E形止メ輪 2.5Fig.No.905ニ含ム	E-Washer	1	1	1	1	1	1	1	1	1	1	1	1	1	1	1	1	1	1	1	
215	MP 00B0 729	W459304	ヒネリバネ Fig.No.905ニ含ム	Safety clutch spring	1	1	1	1	1	1	1	1	1	1	1	1	1	1	1	1	1	1	1	
216	MP 00B0 346	W502776	カミ合せ板 Fig.No.905ニ含ム	Safety clutch plate	1	1	1	1	1	1	1	1	1	1	1	1	1	1	1	1	1	1	1	
217	M9 0604 063	W502778	平 ピ ン 6.35φ×13	Safety clutch plate set pin	1	1	1	1	1	1	1	1	1	1	1	1	1	1	1	1	1	1	1	
218	MP 00B0 952	W459300	連 鎖 板 Fig.No.905ニ含ム	Safety clutch plate rbracket	1	1	1	1	1	1	1	1	1	1	1	1	1	1	1	1	1	1	1	
219	MP 00B1 750	W458199	ブ ッ シ ュ Fig.No.905ニ含ム	Safety clutch bushing	1	1	1	1	1	1	1	1	1	1	1	1	1	1	1	1	1	1	1	
220	M9 1503 007	W501212	棒先丸平ネジ 15/64(28)×10.5	Safety clutch bushing screw	1	1	1	1	1	1	1	1	1	1	1	1	1	1	1	1	1	1	1	
221	M9 1504 002	B 508963	平 ネ ジ 15/64(28)×10	Safety clutch bushing screw	1	1	1	1	1	1	1	1	1	1	1	1	1	1	1	1	1	1	1	
222	MP 00B0 768	W459302	ベルト車(下) Fig.No.905	Belt Pulley(lower)	1	1	1	1	1	1	1	1	1	1	1	1	1	1	1	1	1	1	1	
223	M9 1503 001	B 508971	頭ナシ止メネジ 15/64(28)×4.5	Belt pulley(lower)screw	2	2	2	2	2	2	2	2	2	2	2	2	2	2	2	2	2	2	2	
224	M9 0902 011	W500994	丸皿ネジ 9/64(40)×7	Ball bealing cover plate set screw	3	3	3	3	3	3	3	3	3	3	3	3	3	3	3	3	3	3	3	
225	MN 10A0 771	W461041	玉軸受押エ	Ball bealing cover plate	1	1	1	1	1	1	1	1	1	1	1	1	1	1	1	1	1	1	1	
226	MN 10E0 456	W462945G01	玉軸受(下軸用)	Ball bealing(lower shaft)	1	1	1	1	1	1	1	1	1	1	1	1	1	1	1	1	1	1	1	
227	M9 1603 001	W468269	棒先止メネジ 1/4(40)×5	Ball bealing set screw	1	1	1	1	1	1	1	1	1	1	1	1	1	1	1	1	1	1	1	
228	M9 1602 001	W500036	頭ナシ止メネジ 1/4(40)×4	Ball bealing set screw	1	1	1	1	1	1	1	1	1	1	1	1	1	1	1	1	1	1	1	
229	MP 00B0 347	W459301	カミ合せ車	Gear toothed wheel	1	1	1	1	1	1	1	1	1	1	1	1	1	1	1	1	1	1	1	
265	M9 1606 001	B 504016	頭ナシ止メネジ 1/4(40)×7	Gear toothed wheel set screw	2	2	2	2	2	2	2	2	2	2	2	2	2	2	2	2	2	2	2	
266	M9 0570 065	W461793	E形止メ輪 5	E-Washer	1	1	1	1	1	1	1	1	1	1	1	1	1	1	1	1	1	1	1	
267	MF 30A0 245	W462657	円スイバネ	Push button spring	1	1	1	1	1	1	1	1	1	1	1	1	1	1	1	1	1	1	1	
268	MN 10A0 270	W460512	押シボタン	Push button	1	1	1	1	1	1	1	1	1	1	1	1	1	1	1	1	1	1	1	

DU-100形 針棒と天びん機構部分

NEEDLE BAR & THREAD TAKE-UP LEVER MECHANISM

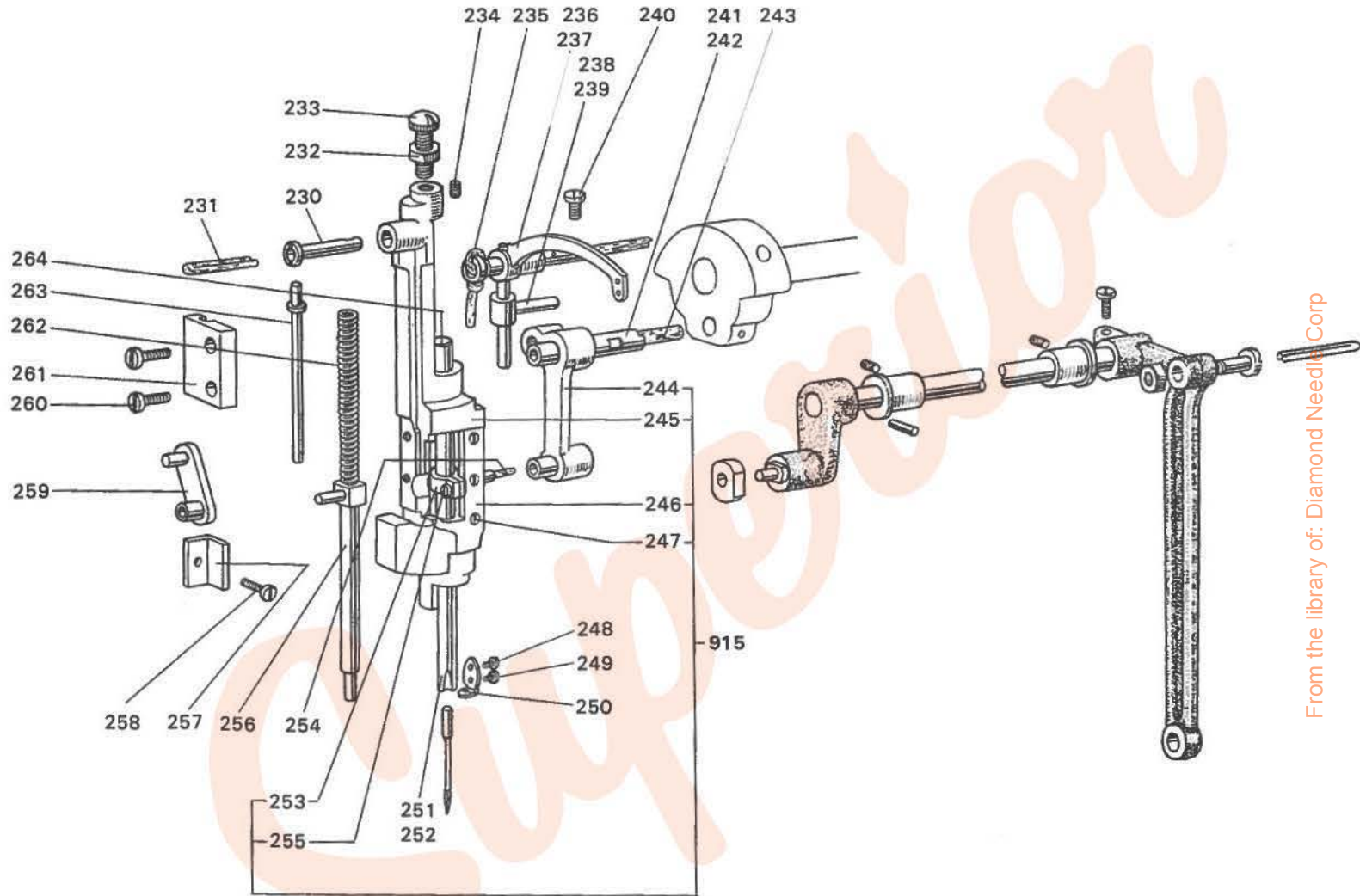

From the library of: Diamond Needle Corp



DU-100形 針棒と天びん機構部分

NEEDLE BAR & THREAD TAKE-UP LEVER MECHANISM

Fig. No.	サービス部品コード Part No.	資材コード Code No.	部 品 名	Name of Part	個 / 台 Amt req													備 考 Remarks						
					DU 100	DU 110	DU 120	DU 105	DU 115	DU 125	DU 103	DU 113	DU 123	DU 108	DU 118	DU 128	DU 102		DU 112	DU 122	DU 107	DU 117	DU 127	
230	MN 10A0 587	W445883	支 エ 軸	Needle bar guide bracket rod	2	2	2	2	2	2	2	2	2	2	2	2	2	2	2	2	2	2	2	
231	MF 10E0 148	W462979	油 ヒ モ 2.5φ×80	Oil wick	1	1	1	1	1	1	1	1	1	1	1	1	1	1	1	1	1	1	1	
232	M9 1251 045	B 509177	ナ ッ ト 3/16(32)×3	Thumb screw nut	1	1	1	1	1	1	1	1	1	1	1	1	1	1	1	1	1	1	1	
233	M9 1201 035	W502464	ツ マ ミ ネ ジ 3/16(32)×39	Thumb screw	1	1	1	1	1	1	1	1	1	1	1	1	1	1	1	1	1	1	1	
234	M9 1506 001	B 509087	頭ナシ止メネジ 15/64(28)×7	Needle bar guide bracket rod screw	1	1	1	1	1	1	1	1	1	1	1	1	1	1	1	1	1	1	1	
235	MF 10E2 148	W444138	油 ヒ モ 2.5φ×240	Oil wick	1	1	1	1	1	1	1	1	1	1	1	1	1	1	1	1	1	1	1	
236	MP 00B0 582	W462789	天 ビ ン	Thread take-up	1	1	1	1	1	1	1	1	1	1	1	1	1	1	1	1	1	1	1	
	MP 02B0 582	W473547	天 ビ ン	Thread take-up	1	1	1	1	1	1	1	1	1	1	1	1	1	1	1	1	1	1	1	
237	MP 03B0 582	W459309	天 ビ ン	Thread take-up	1	1	1	1	1	1	1	1	1	1	1	1	1	1	1	1	1	1	1	
238	MN 10A0 588	W445881	天ビンスベリ	Thread take-up link	1	1	1	1	1	1	1	1	1	1	1	1	1	1	1	1	1	1	1	
239	MP 03B0 588	W462924	天ビンスベリ	Thread take-up link	1	1	1	1	1	1	1	1	1	1	1	1	1	1	1	1	1	1	1	
240	M9 1502 002	W500509	平 ネ ジ 15/64(28)×8.5	Screw(for Fig.236,237)	1	1	1	1	1	1	1	1	1	1	1	1	1	1	1	1	1	1	1	
241	MN 10A0 387	W445866	クランクピン	Needle bar crank pin	1	1	1	1	1	1	1	1	1	1	1	1	1	1	1	1	1	1	1	
242	MP 00B0 387	W459399	クランクピン	Needle bar crank pin	1	1	1	1	1	1	1	1	1	1	1	1	1	1	1	1	1	1	1	
243	MN 10A1 740	W500801	フェルト	Felt(for Fig.241,242)	1	1	1	1	1	1	1	1	1	1	1	1	1	1	1	1	1	1	1	
915	MP 00E0 666	W220605Z01	針棒支工(組)	Needle bar guide bracket(complete)	1	1	1	1	1	1	1	1	1	1	1	1	1	1	1	1	1	1	1	
244	MP 00B0 661	W326221	針棒クランクロッド Fig.No.915ニ含ム	Needle bar crank rod	1	1	1	1	1	1	1	1	1	1	1	1	1	1	1	1	1	1	1	
245	MP 00B0 666	W220605	針棒支工(組)	Needle bar guide bracket	1	1	1	1	1	1	1	1	1	1	1	1	1	1	1	1	1	1	1	
246	MP 00B0 476	W454800	スペーサー	Spacer	2	2	2	2	2	2	2	2	2	2	2	2	2	2	2	2	2	2	2	
247	M9 0604 011	W501205	丸皿ネジ 3/32(56)×4	Spacer set screw	5	5	5	5	5	5	5	5	5	5	5	5	5	5	5	5	5	5	5	
248	M9 0602 002	W501567	平ネジ 3/32(56)×3	Needle bar thread guide set screw	1	1	1	1	1	1	1	1	1	1	1	1	1	1	1	1	1	1	1	
249	M9 0801 002	W501391	平ネジ 1/8(44)×3	Needle bar thread guide set screw	1	1	1	1	1	1	1	1	1	1	1	1	1	1	1	1	1	1	1	
250	MP 00B1 181	W457584	針棒糸カケ	Needle bar thread guide	1	1	1	1	1	1	1	1	1	1	1	1	1	1	1	1	1	1	1	
251	MP 00B0 660	W446382	針棒 Fig.No.915ニ含ム	Needle bar	1	1	1	1	1	1	1	1	1	1	1	1	1	1	1	1	1	1	1	
252	MP 20B0 660	W457556	針棒 Fig.No.915ニ含ム	Needle bar	1	1	1	1	1	1	1	1	1	1	1	1	1	1	1	1	1	1	1	
253	MP 00B0 665	W462920	針棒ダキ Fig.No.915ニ含ム	Needle bar holder	1	1	1	1	1	1	1	1	1	1	1	1	1	1	1	1	1	1	1	
254	MN 10A0 740	W500499	フェルト	Felt(for Fig.244)	1	1	1	1	1	1	1	1	1	1	1	1	1	1	1	1	1	1	1	
255	M9 0905 002	W500470	平ネジ 9/64(40)×8.5	Needle bar holder set screw	1	1	1	1	1	1	1	1	1	1	1	1	1	1	1	1	1	1	1	
256	MP 00B0 881	W453588	揺動押工棒	Vibrating presser bar	1	1	1	1	1	1	1	1	1	1	1	1	1	1	1	1	1	1	1	
257	MP 00B0 667	W453582	針棒支工ガイド	Needle bar guide	1	1	1	1	1	1	1	1	1	1	1	1	1	1	1	1	1	1	1	
258	M9 1105 002	W500450	平ネジ 11/64(40)×10	Needle bar guide set screw	1	1	1	1	1	1	1	1	1	1	1	1	1	1	1	1	1	1	1	
259	MP 00B0 882	W453587	揺動押工棒リンク	Vibrating presser bar link	1	1	1	1	1	1	1	1	1	1	1	1	1	1	1	1	1	1	1	
260	M9 1113 002	W500182	平ネジ 11/64(40)×15	Vibrating presser bar guide set screw	2	2	2	2	2	2	2	2	2	2	2	2	2	2	2	2	2	2	2	
261	MP 00B0 883	W453581	揺動押工棒案内	Vibrating presser bar guide	1	1	1	1	1	1	1	1	1	1	1	1	1	1	1	1	1	1	1	
262	MH 19A0 259	W462921	押エバネ	Presser spring	1	1	1	1	1	1	1	1	1	1	1	1	1	1	1	1	1	1	1	
263	MP 00B0 884	W453589	揺動押エバネ案内	Vibrating presser spring guide	1	1	1	1	1	1	1	1	1	1	1	1	1	1	1	1	1	1	1	
264	MN 10A0 500	W501275	栓	Needle bar cap	1	1	1	1	1	1	1	1	1	1	1	1	1	1	1	1	1	1	1	

DU-100形 針棒搖動機構部分  
 NEEDLE BAR ROCKING MOTION MECHANISM

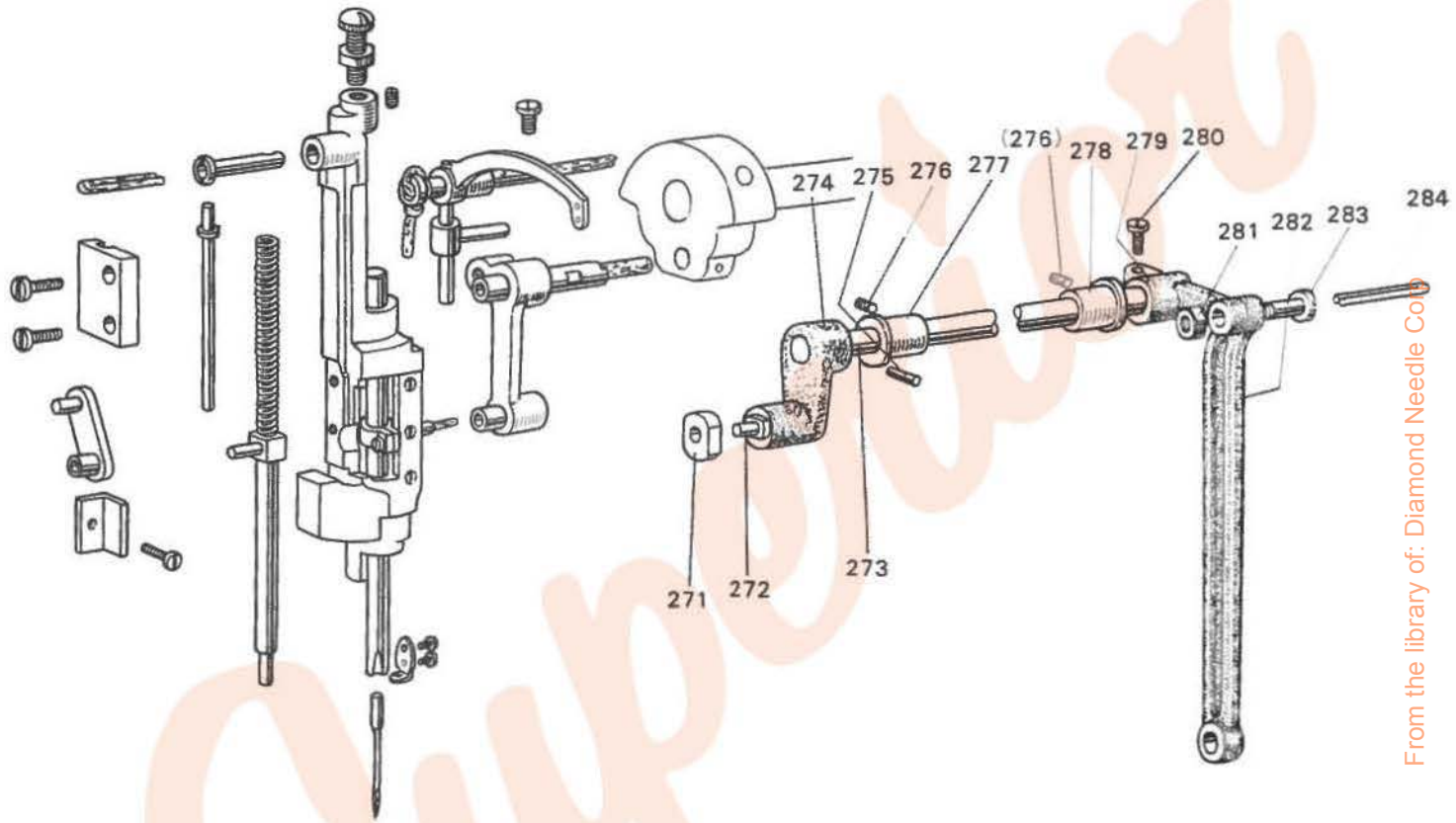

From the library of: Diamond Needle Co.



DU-100形 針棒揺動機構部分

NEEDLE BAR ROCKING MOTION MECHANISM

Fig. No.	サービス部品コード Part No.	資材コード Code No.	部 品 名	Name of Part	個 / 台 Amt. req													備 考 Remarks						
					DU-100	DU-110	DU-120	DU-105	DU-115	DU-125	DU-103	DU-113	DU-123	DU-108	DU-118	DU-128	DU-102		DU-112	DU-107	DU-117	DU-127		
271	MN 25A0 325	W502443	角 駒	Square block	1	1	1	1	1	1	1	1	1	1	1	1	1	1	1	1	1	1	1	
272	M9 0509 063	W502445	揺 動 ビ ン 15/64(28)×24	Needle bar vibrating crank pin	1	1	1	1	1	1	1	1	1	1	1	1	1	1	1	1	1	1	1	
273	MN 10A0 668	W445872	針 棒 揺 動 軸	Needle bar vibrating shaft	1	1	1	1	1	1	1	1	1	1	1	1	1	1	1	1	1	1	1	
274	MP 00B0 672	W453583	針 棒 揺 動 腕(左)	Needle bar vibrating crank(left)	1	1	1	1	1	1	1	1	1	1	1	1	1	1	1	1	1	1	1	
275	M9 0401 061	W501209	テ ー パ ビ ン 4φ×23×1/50	Taper pin	1	1	1	1	1	1	1	1	1	1	1	1	1	1	1	1	1	1	1	
276	M9 1653 001	W500478	頭ナシ止メネジ 1/4(24)×8	Needle bar vibrating shaft shaft bushing(left)set screw	2	2	2	2	2	2	2	2	2	2	2	2	2	2	2	2	2	2	2	
277	MN 10A0 669	W462919	針棒揺動軸メタル(左)	Needle bar vibratig shaft bushing(left)	1	1	1	1	1	1	1	1	1	1	1	1	1	1	1	1	1	1	1	
278	MN 10A1 669	W445871	針棒揺動軸メタル(右)	Needle bar vibrating shaft bushing(right)	1	1	1	1	1	1	1	1	1	1	1	1	1	1	1	1	1	1	1	
279	MP 00B1 672	W453584	針 棒 揺 動 腕(右)	Needle bar vibrating crank(right)	1	1	1	1	1	1	1	1	1	1	1	1	1	1	1	1	1	1	1	
280	M9 1603 003	W501009	丸 平 ネ ジ 1/4(24)×16	Needle bar vibrating crank(right)set screw	1	1	1	1	1	1	1	1	1	1	1	1	1	1	1	1	1	1	1	
281	M9 2002 045	W501187	ナ ッ ト 5/16(24)×5.5	Needle bar vibrating connecting rod nut	1	1	1	1	1	1	1	1	1	1	1	1	1	1	1	1	1	1	1	
282	MP 00B0 671	W453585	針棒揺動連結棒	Needle bar Vibrating connecting rod	1	1	1	1	1	1	1	1	1	1	1	1	1	1	1	1	1	1	1	
283	M9 2001 015	W501010	段 付 平 ネ ジ 5/16(24)×26.2	Needle bar vibrating connecting rod hinge screw	1	1	1	1	1	1	1	1	1	1	1	1	1	1	1	1	1	1	1	
284	MF 10E2 148	W462978	油 ヒ モ 2.5φ×85	Oil wick	1	1	1	1	1	1	1	1	1	1	1	1	1	1	1	1	1	1	1	

From the library of: Diamond Needle Corp.

DUクラス かま機構部分 ROTATING HOOK MECHANISM

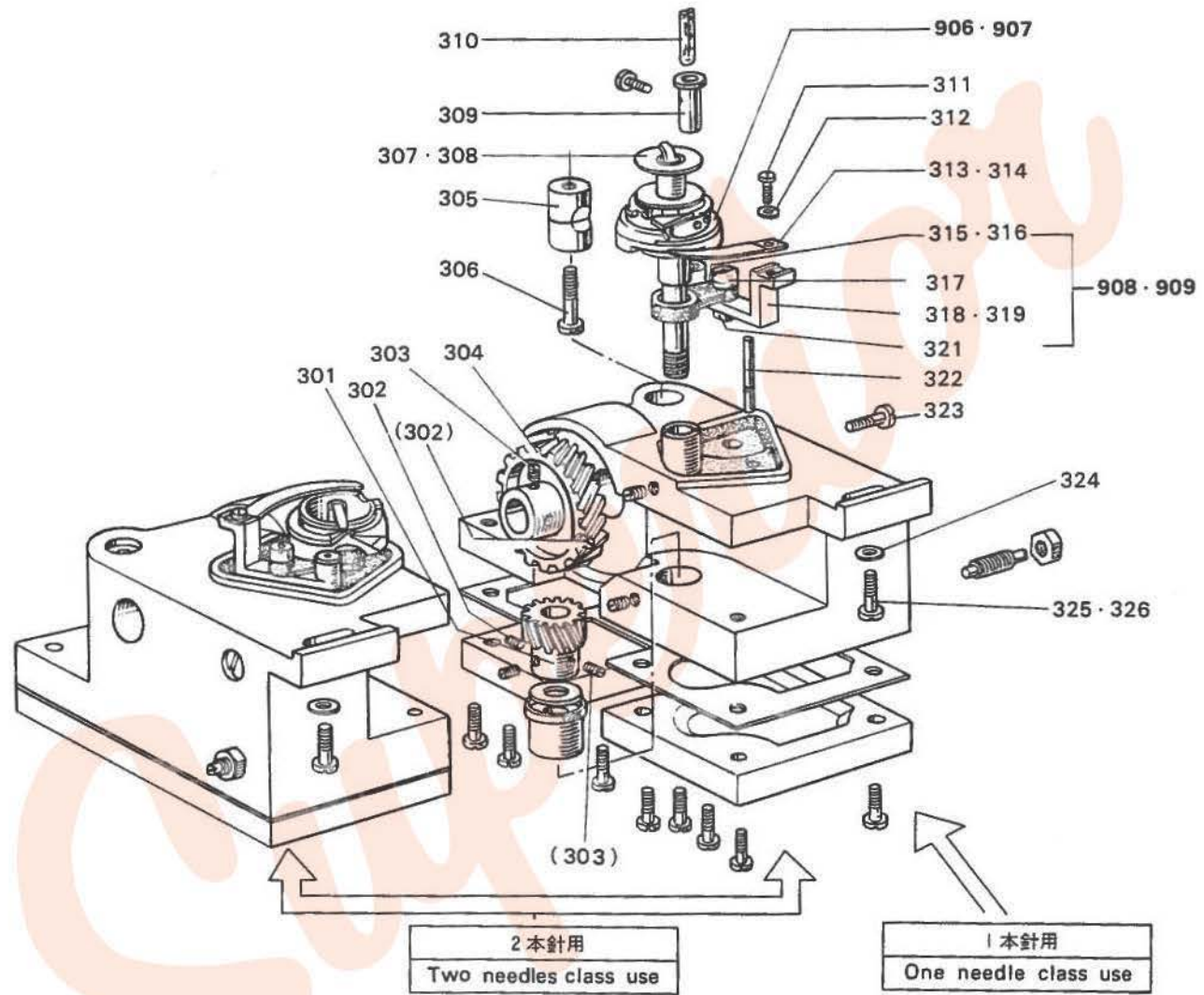

From the library of: Diamond Needle Corp



DUクラス かま機構部分

ROTATING HOOK MECHANISM

Fig No.	サービス部品コード Part No.	資材コード Code No.	部 品 名	Name of Part	個 / 台 Amt req													備 考 Remarks					
					DU-100	DU-110	DU-120	DU-105	DU-115	DU-125	DU-103	DU-113	DU-123	DU-108	DU-118	DU-128	DU-102		DU-112	DU-122	DU-107	DU-117	DU-127
301	MP 00B0 643	W462926	ネジ歯車(小)	Hook driving shaft bevel gear(small)	1	1	2	1	1	2	1	1	2	1	1	2	1	1	2	1	1	2	
302	M9 1602 001	W500036	頭ナシ止メネジ 1/4(40)×4	Hook driving shaft bevel gear(small)set screw	3	3	6	3	3	6	3	3	6	3	3	6	3	3	6	3	3	6	
303	M9 1604 005	W464477	棒先止メネジ 1/4(40)×8	Hook driving shaft bevel gear(small)set screw	2	2	4	2	2	4	2	2	4	2	2	4	2	2	4	2	2	4	
304	MP 00B0 642	W326226	ネジ歯車(大)	Hook driving shaft bevel gear(large)	1	1	2	1	1	2	1	1	2	1	1	2	1	1	2	1	1	2	
305	MP 0030 750	W445905	締付ケブッシュ	Hook driving shaft bushing	1	1	2	1	1	2	1	1	2	1	1	2	1	1	2	1	1	2	
306	M9 1509 002	B 509074	平ネジ 15/64(28)×30	Hook driving shaft bushing set screw	1	1	2	1	1	2	1	1	2	1	1	2	1	1	2	1	1	2	
906	MP 00B0 120	W326227	カマ KRT11-5M	Rotating hook	1	1	2	1	1	2													
	MP 02B0 120	P 975000X01	カマ KRT11-5M	Rotating hook																			
907	MP 03B0 120	W326228	カマ 445-M	Rotating hook																			
307	MN 10A0 123	W445964	ボビン	Bobbin	1	1	2	1	1	2													
	MN 02A0 123	W462929	ボビン	Bobbin																			
308	MP 03B0 123	W462928	ボビン	Bobbin																			
309	MN 10A0 302	W445901	オープナーササエ軸	Rotating hook opener bracket shaft	1	1	2	1	1	2	1	1	2	1	1	2	1	1	2	1	1	2	
310	MF 10E2 148	W462980	油ヒモ 2.5φ×15	Oil wick	1	1	2	1	1	2	1	1	2	1	1	2	1	1	2	1	1	2	
311	M9 0910 003	B 509270	丸平ネジ 9/64(40)×7	Screw	1	1	2	1	1	2	1	1	2	1	1	2	1	1	2	1	1	2	
312	M9 0401 050	B 508956	座金	Washer	1	1	2	1	1	2	1	1	2	1	1	2	1	1	2	1	1	2	
313	MN 10A0 300	W445903	オープナー	Rotating hook opener	1	1	2	1	1	2													
314	MP 03B0 300	W459313	オープナー	Rotating hook opener																			
315	MN 10A0 340	W445900	カマノクランク腕	Rotating hook connecting crank	1	1	2	1	1	2													
316	MP 03B0 340	W459314	カマノクランク腕	Rotating hook connecting crank																			
908	MN 10E0 301	W458147	オープナーササエ(組)	Rotating hook opener bracket complete	1	1	2	1	1	2													
	MN 12E0 301	W462938	オープナーササエ(組)	Rotating hook opener bracket complete																			
909	MP 03E0 300	W461034	オープナーササエ(組)	Rotating hook opener bracket complete																			
317	M9 1254 030	W445904	オープナーササエピン	Rotating hook opener bracket pin	1	1	2	1	1	2	1	1	2	1	1	2	1	1	2	1	1	2	
318	MN 10A0 301	W445902	オープナーササエ	Rotating hook opener bracket	1	1	2	1	1	2													
	MN 12B0 301	W459390	オープナーササエ	Rotating hook opener bracket																			
319	MP 03B0 301	W459312	オープナーササエ	Rotating hook opener bracket																			
320	M9 0501 051	W462760	歯付座金	Teethed washer	1	1	2	1	1	2	1	1	2	1	1	2	1	1	2	1	1	2	
321	M9 1251 045	B 509177	ナット 3/16(32)×3	Nut	1	1	2	1	1	2	1	1	2	1	1	2	1	1	2	1	1	2	
322	MN 10A0 250	W502458	オイルゲージ	Oil gauge	1	1	2	1	1	2	1	1	2	1	1	2	1	1	2	1	1	2	
323	M9 1204 002	W501726	平ネジ 3/16(28)×18	Hook saddle(right)screw	1	1	2	1	1	2	1	1	2	1	1	2	1	1	2	1	1	2	
324	M9 0701 050	B 509331	座金	Hook saddle(right)set screw washer	1	1	2	1	1	2	1	1	2	1	1	2	1	1	2	1	1	2	
325	M9 1652 002	W501208	平ネジ 1/4(24)×28	Hook saddle(right)set screw	1	1	2	1	1	2													
326	M9 1651 002	W462939	平ネジ 1/4(24)×23	Hook saddle(right)set screw																			

DUクラス かま機構部分 ROTATING HOOK MECHANISM

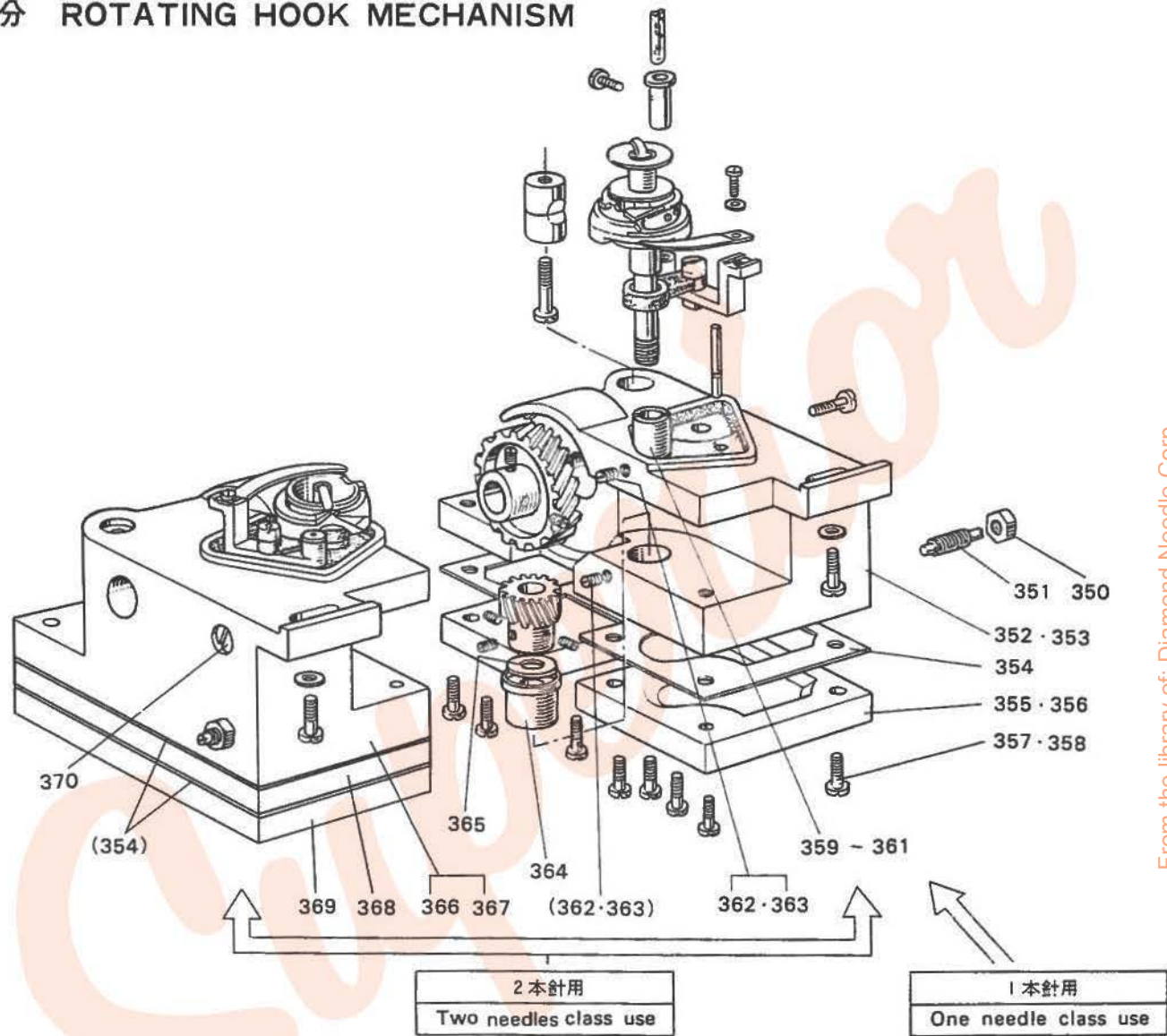

From the library of: Diamond Needle Corp



DUクラス かま機構部分

ROTATING HOOK MECHANISM

Fig. No.	サービス部品コード Part No.	資材コード Code No.	部 品 名	Name of Part	個 / 台 Amt. req												備 考 Remarks									
					DU-100	DU-110	DU-120	DU-105	DU-115	DU-125	DU-103	DU-113	DU-123	DU-108	DU-118	DU-128		DU-102	DU-112	DU-122	DU-107	DU-117	DU-127			
350	M9 1251 045	B 509177	ナ ッ ト 3/16(32)×3	Hook saddle(right)set screw nut	1	1	2	1	1	2	1	1	2	1	1	2	1	1	2	1	1	2				
351	M9 1252 030	W502747	コ ッ ク ネ ジ 3/16(32)×28.5	Hook saddle(right)cock screw	1	1	2	1	1	2	1	1	2	1	1	2	1	1	2	1	1	2				
352	MN 10A0 345	W220612	カ マ 台(右)	Hook saddle(right)	1	1	1	1	1	1																
	MN 12B0 345	W220606	カ マ 台(右)	Hook saddle(right)													1	1	1	1	1	1				
353	MP 03B0 345	W220624	カ マ 台(右)	Hook saddle(right)							1	1	1	1	1											
354	MN 10A0 691	W445895	バ ッ キ ン	Hook saddle gasket	1	1	2	1	1	2	1	1	2	1	1	2	1	1	2	1	1	2				
355	MP 00B0 134	W445893	油 ン タ (カマ台右)	Oil reservoir cover(right)	1	1	1	1	1	1									1	1	1	1				
356	MP 03B0 132	W459310	油 ン タ (カマ台右)	Oil reservoir cover(right)							1	1	1	1	1											
357	M9 1201 004	W469526	ブ ラ マ イ ネ ジ 3/16(28)×11	Oil reservoir cover(right)set screw	8	8	6	8	8	6									8	8	6	8	8	6		
358	M9 1203 002	B 509178	平 ネ ジ 3/16(28)×15	Oil reservoir cover(right)set screw							8	8	6	8	8	6										
359	MN 10A0 342	W445898	カマ軸メタル(上)	Hook shaft bushing(upper)	1	1	2	1	1	2																
	MN 12B0 342	W462940	カマ軸メタル(上)	Hook shaft bushing(upper)															1	1	2	1	1	2		
360			座 金	Hook shaft bracket washer							1	1	2	1	1	2										
361	M9 0108 070	W468261	軸 受(組) <SC-65ベアリング>	Hook shaft bracket complete							1	1	2	1	1	2										
362	M9 1503 001	B 508971	頭ナシ止メネジ 15/64(28)×4.5	Hook saddle(right)screw	1	1	4	1	1	4									1	1	4	1	1	4		
363	M9 1106 001	W509266	頭ナシ止メネジ 11/64(40)×4.3	Hook saddle(right)screw							1	1	4	1	1	4										
364	MN 10A0 343	W445899	カマ軸メタル(下)	Hook shaft bushing(lower)	1	1	2	1	1	2	1	1	2	1	1	2	1	1	2	1	1	2	1	1	2	
365	M9 1001 050	W501041	座 金	Hook shaft bushing(lower)washer	1	1	2	1	1	2	1	1	2	1	1	2	1	1	2	1	1	2	1	1	2	
366	MN 10A0 344	W220611	カ マ 台(左)	Hook saddle(left)				1																		
	MN 12B0 344	W220606	カ マ 台(左)	Hook saddle(left)															1							
367	MP 23B0 344	W220629	カ マ 台(左)	Hook saddle										1		1										
368	MP 20B1 133	W459398	油 ン タ (左)(スペーサー)	Oil resevoir cover(left)(spacer)										1		1										
369	MP 20B0 133	W445896	油 ン タ (左)	Oil resevoir cover(left)							1									1						
370	M9 9026 002	W462941	平 ネ ジ 9/64(40)×19	Hook saddle(left)screw	1	1	2	1	1	2	1	1	2	1	1	2	1	1	2	1	1	2	1	1	2	

From the library of: Diamond Needle Corp

DU-100/110/120形 下軸と縫い目加減機構部分  
 LOWER SHAFT & STITCH REGULATOR MECHANISM

DU-100 110 120 クラス用
DU-100 110 120 Class use

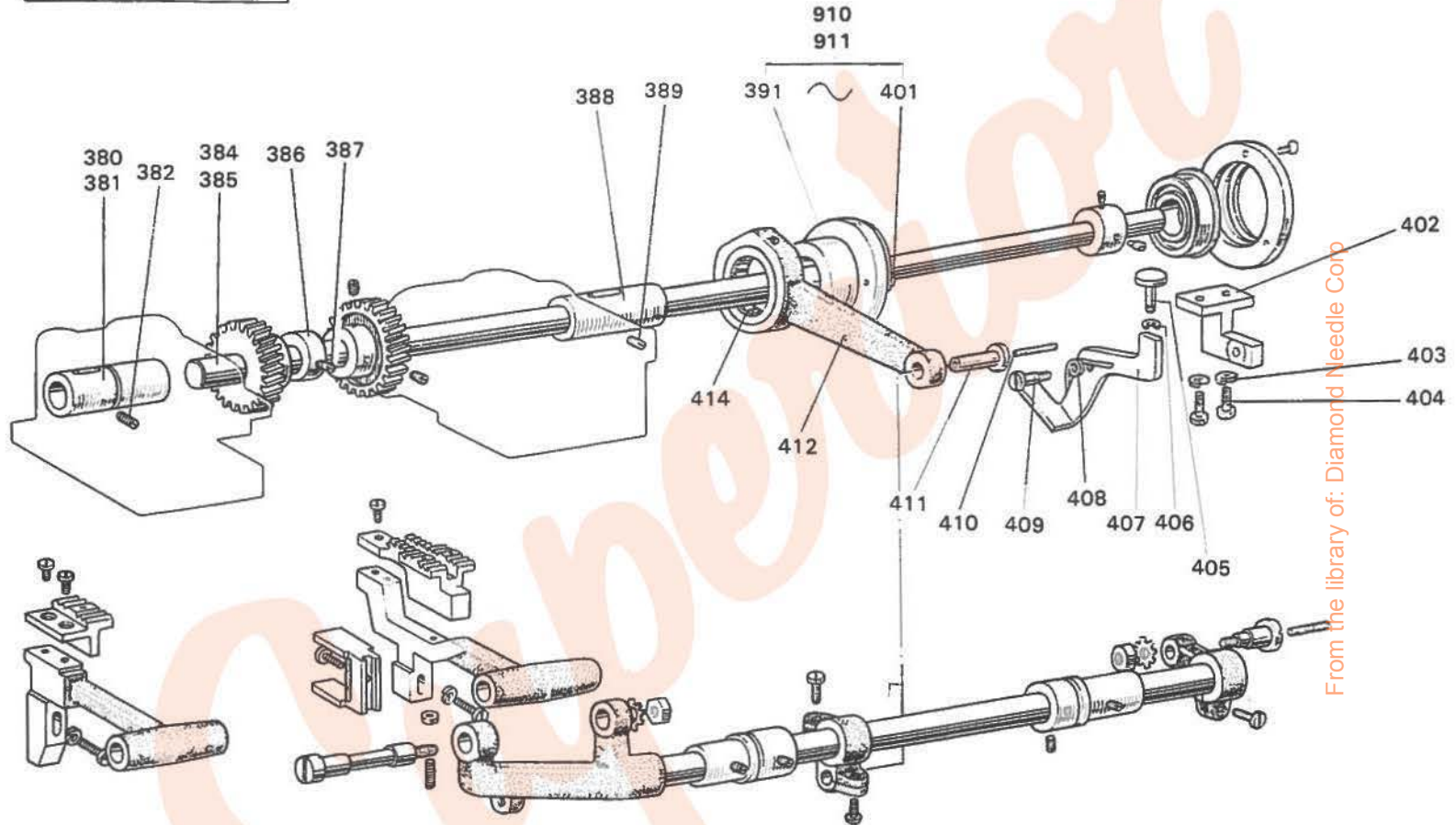

From the library of: Diamond Needle Corp



DU-100/110/120形 下軸と縫い目加減機構部分

LOWER SHAFT & STITCH REGULATOR MECHANISM

Fig. No.	サービス部品コード Part No.	資材コード Code No.	部 品 名	Name of Part	個/台 Amt. req.													備 考 Remarks					
					DU-100	DU-110	DU-120	DU-105	DU-115	DU-125	DU-103	DU-113	DU-123	DU-108	DU-118	DU-128	DU-102		DU-112	DU-122	DU-107	DU-117	DU-127
380	MN 10AO 451	W445890	下軸メタル(左)	Lower shaft bushing(left)	1	1	1	1	1	1	1	1	1	1	1	1	1	1	1	1	1	1	
381	MP 10BO 451	W454878	下軸メタル(左)	Lower shaft bushing(left)	1	1	1	1	1	1	1	1	1	1	1	1	1	1	1	1	1	1	
382	M9 1654 001	W501017	頭ナシ止メネジ 1.4(24)×13.8	Lower shaft bushing(left)set screw	1	1	1	1	1	1	1	1	1	1	1	1	1	1	1	1	1	1	
383	MF 10EO 148	W462978	油 ヒ モ 2.5φ×85	Oil wick	2	2	2	2	2	2	2	2	2	2	2	2	2	2	2	2	2	2	
384	MN 10AO 450	W445889	下 軸	Lower shaft	1	1	1	1	1	1	1	1	1	1	1	1	1	1	1	1	1	1	
385	MP 10BO 450	W462943	下 軸	Lower shaft	1	1	1	1	1	1	1	1	1	1	1	1	1	1	1	1	1	1	
386	MN 10AO 292	W445912	送り上下カム	Feed lifting cam	1	1	1	1	1	1	1	1	1	1	1	1	1	1	1	1	1	1	
387	M9 1652 001	W501385	棒先止メネジ 1.4(24)×5.5	Feed lifting cam set screw	1	1	1	1	1	1	1	1	1	1	1	1	1	1	1	1	1	1	
388	MN 10AO 452	W445891	下軸メタル(右)	Lower shaft bushing(right)	1	1	1	1	1	1	1	1	1	1	1	1	1	1	1	1	1	1	
389	M9 1654 001	W501017	頭ナシ止メネジ 1/4(24)×13.8	Lower shaft bushing(right)set screw	1	1	1	1	1	1	1	1	1	1	1	1	1	1	1	1	1	1	
910	MN 10EO 290	W462944	送り調節器(組)	Feed regulator complete	1	1	1	1	1	1	1	1	1	1	1	1	1	1	1	1	1	1	
911	MP 05EO 290	W331017	送り調節器(組)	Feed regulator complete	1	1	1	1	1	1	1	1	1	1	1	1	1	1	1	1	1	1	
391		W450960	カ ラ ー 送り調節器ニ含ム	Feed connection rod collar	1	1	1	1	1	1	1	1	1	1	1	1	1	1	1	1	1	1	
392		W500706	頭ナシ止メネジ 送り調節器組ニ含ム	Feed connection rod collar set	2	2	2	2	2	2	2	2	2	2	2	2	2	2	2	2	2	2	
393		W502945	平 ネ ジ 送り調節器組ニ含ム	Feed connection rod collar set screw	2	2	2	2	2	2	2	2	2	2	2	2	2	2	2	2	2	2	
394		W453593	駆 動 輪 送り調節器ニ含ム	Feed rock shaft cam	1	1	1	1	1	1	1	1	1	1	1	1	1	1	1	1	1	1	
395		W453594	偏 心 輪 送り調節器ニ含ム	Eccentric link	1	1	1	1	1	1	1	1	1	1	1	1	1	1	1	1	1	1	
396			偏 心 輪 送り調節器ニ含ム	Eccentric link	1	1	1	1	1	1	1	1	1	1	1	1	1	1	1	1	1	1	
397		W501163	ヒネリバネ 送り調節器組ニ含ム	Clutch plate spring	1	1	1	1	1	1	1	1	1	1	1	1	1	1	1	1	1	1	
398	M9 0901 015	W501162	段付平ネジ 9/64(40)×6	Clutch plate spring screw	1	1	1	1	1	1	1	1	1	1	1	1	1	1	1	1	1	1	
399		W446370	クラッチ板 送り調節器ニ含ム	Clutch plate	1	1	1	1	1	1	1	1	1	1	1	1	1	1	1	1	1	1	
400		W446371	カバ ー 板 送り調節器ニ含ム	Clutch plate cover	1	1	1	1	1	1	1	1	1	1	1	1	1	1	1	1	1	1	
401		W500791	平 ネ ジ 送り調節器ニ含ム	Clutch plate cover set screw	2	2	2	2	2	2	2	2	2	2	2	2	2	2	2	2	2	2	
402	MN 10AO 951	W453591	レバ ー 台<取付台>	Lever bracket	1	1	1	1	1	1	1	1	1	1	1	1	1	1	1	1	1	1	
403	M9 0401 053	W462617	バネ座金 4	Lever bracket set screw washer	2	2	2	2	2	2	2	2	2	2	2	2	2	2	2	2	2	2	
404	M9 1113 002	W500182	平 ネ ジ 11/64(40)×15	Lever bracket set screw	2	2	2	2	2	2	2	2	2	2	2	2	2	2	2	2	2	2	
405	MN 10AO 270	W460512	押シボタン	Push button	1	1	1	1	1	1	1	1	1	1	1	1	1	1	1	1	1	1	
406	M9 0505 065	W461793	E形止メ輪 5	Bush button washer(E)	1	1	1	1	1	1	1	1	1	1	1	1	1	1	1	1	1	1	
407	MN 10AO 269	W461027	押シボタンレバー	Push button lever	1	1	1	1	1	1	1	1	1	1	1	1	1	1	1	1	1	1	
408	MN 10A2 729	W502469	ヒネリバネ	Push button lever spring	1	1	1	1	1	1	1	1	1	1	1	1	1	1	1	1	1	1	
409	M9 1104 015	W500205	段付平ネジ 11/64(40)×14.5	Push button lever set screw	1	1	1	1	1	1	1	1	1	1	1	1	1	1	1	1	1	1	
410	MF 10E3 148	W500231	油 ヒ モ 3φ×25	Oil wick	1	1	1	1	1	1	1	1	1	1	1	1	1	1	1	1	1	1	
411	M9 0707 063	W501015	ピ ン 7.94φ×22.5	Feed connection rod set pin	1	1	1	1	1	1	1	1	1	1	1	1	1	1	1	1	1	1	
412	MN 10EO 293	W445906	送りロッド(組)	Feed connection rod complete	1	1	1	1	1	1	1	1	1	1	1	1	1	1	1	1	1	1	
413	MP 05EO 293	W460585	送りロッド(組) (25頁参照)	Feed connection rod complete	1	1	1	1	1	1	1	1	1	1	1	1	1	1	1	1	1	1	
414	M9 1004 070	NTN SC 28	ニードルベアリング 送りロッド組ニ含ム	Needle bearing	2	2	2	2	2	2	2	2	2	2	2	2	2	2	2	2	2	2	

DU-100/110/120形 送り機構部分  
 FEED ROCKING MOTION MECHANISM

1本針用  
 One needle class use

2本針用  
 Two needles class use

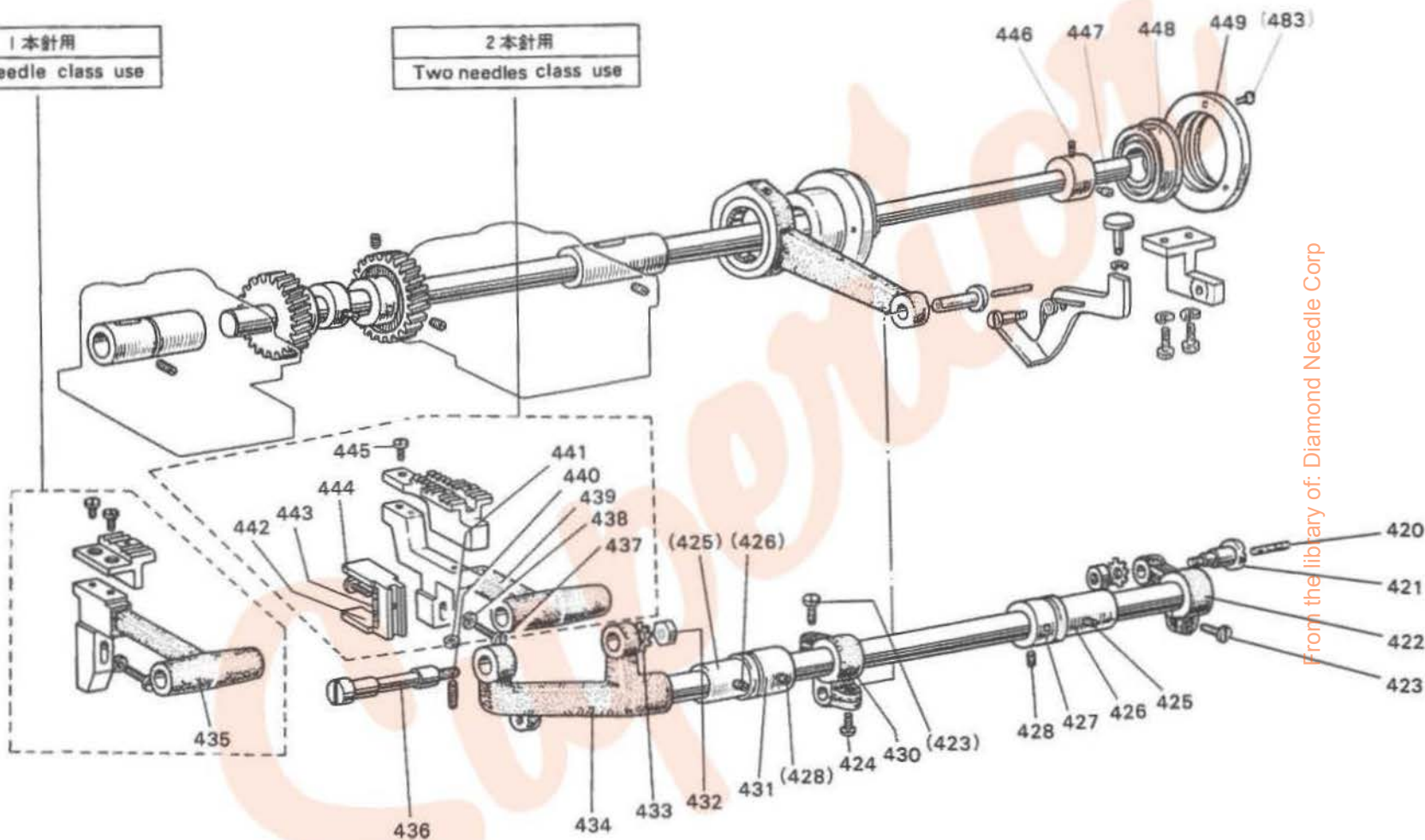

From the library of: Diamond Needle Corp



DU-100/110/120形 送り機構部分

FEED ROCKING MOTION MECHANISM

Fig. No.	サービス部品コード Part No.	資材コード Code No.	部 品 名	Name of Part	個 / 台 Amt. req													備 考 Remarks					
					DU-100	DU-110	DU-120	DU-105	DU-115	DU-125	DU-103	DU-113	DU-123	DU-108	DU-118	DU-128	DU-102		DU-112	DU-122	DU-107	DU-117	DU-127
420	MF 10E3 148	W500231	油 ヒ モ 3φ×25	Oil wick	1	1	1	1	1	1	1	1	1	1	1	1	1	1	1	1	1	1	
421	M9 0707 063	W501015	ビ ン 7.94φ×22.5	Feed connection crank pin	1	1	1	1	1	1	1	1	1	1	1	1	1	1	1	1	1	1	
422	MP 00B0 273	W462947	送 リ 腕(右)	Feed connection crank(right)	1	1	1	1	1	1	1	1	1	1	1	1	1	1	1	1	1	1	
423	M9 1603 003	W501009	丸 平 ネ ジ 1/4(24)×16	Feed connection crank(right)set screw	3	3	3	3	3	3	3	3	3	3	3	3	3	3	3	3	3	3	
424	M9 1203 002	B 509178	平 ネ ジ 3/16(28)×15	Feed connection crank pin set screw	3	3	3	3	3	3	3	3	3	3	3	3	3	3	3	3	3	3	
425	M9 1653 001	W500478	頭ナシ止メネジ 1/4(24)×8	Feed rock shaft bushing set screw	2	2	2	2	2	2	2	2	2	2	2	2	2	2	2	2	2	2	
426	MP 00B0 285	W445910	送 リ 軸 メタル	Feed rock shaft bushing	2	2	2	2	2	2	2	2	2	2	2	2	2	2	2	2	2	2	
427	MP 00B0 352	W445954	カ ラ ー	Feed rock shaft bushing collar	1	1	1	1	1	1	1	1	1	1	1	1	1	1	1	1	1	1	
428	M9 1503 001	B 508971	頭ナシ止メネジ 15/64(28)×4.5	Feed rock shaft bushing collar set screw	4	4	4	4	4	4	4	4	4	4	4	4	4	4	4	4	4	4	
429	MP 00B0 273	W462947	送 リ 腕(左) (25頁参照)	Feed connection crank(left)				1	1	1				1	1	1				1	1	1	
430	MP 00B0 274	W462948	送 リ 腕(左)	Feed connection crank(left)	1	1	1				1	1	1				1	1	1				
431	MP 00B0 352	W445954	カ ラ ー	Feed rock shaft bushing collar	1	1	1	1	1	1	1	1	1	1	1	1	1	1	1	1	1	1	
432	M9 1602 045	W501058	ナ ッ ト 1/4(28)×5.5	Nut	1	1	1	1	1	1	1	1	1	1	1	1	1	1	1	1	1	1	
433	M9 0601 051	W462950	歯 付 座 金 B6	Teethed washer	1	1	1	1	1	1	1	1	1	1	1	1	1	1	1	1	1	1	
434	MN 10A0 284	W319986	送 リ 軸	Feed rock shaft	1	1	1	1	1	1	1	1	1	1	1	1	1	1	1	1	1	1	
435	MP 00B0 281	W322719	送 リ 台	Feed bar	1	1	1	1	1	1	1	1	1	1	1	1	1	1	1	1	1	1	
436	MN 10A0 283	W445911	送 リ 台 支 工 軸	Feed bar shaft	1	1	1	1	1	1	1	1	1	1	1	1	1	1	1	1	1	1	
437	M9 1503 002	W501002	丸 平 ネ ジ 15/64(28)×13	Feed bar screw	1	1	1	1	1	1	1	1	1	1	1	1	1	1	1	1	1	1	
438	M9 0604 050	W500645	座 金	Feed bar washer	1	1	1	1	1	1	1	1	1	1	1	1	1	1	1	1	1	1	
439	MN 10A0 281	W459348	送 リ 台	Feed bar			1				1			1			1			1			
440	M9 0851 001	W501001	頭ナシ止メネジ 1/8(40)×15	Feed bar screw			1				1			1			1			1			
441	M9 0801 045	W501210	ナ ッ ト 1/8(40)×3	Feed bar nut			1				1			1			1			1			
442	MN 10A0 282	W445913	送 リ 台 ニ ヌ	Feed bar forked connection	1	1	1	1	1	1	1	1	1	1	1	1	1	1	1	1	1	1	
443	MN 10A3 740	W501011	フ ェ ル ト	Feed bar forked connection felt	1	1	1	1	1	1	1	1	1	1	1	1	1	1	1	1	1	1	
444	M9 0804 003	W501003	丸 平 ネ ジ 1/8(44)×4	Feed bar forked connection set screw	1	1	1	1	1	1	1	1	1	1	1	1	1	1	1	1	1	1	
445	M9 0851 002	W501000	平 ネ ジ 1/8(40)×7	Feed dog set screw	2	2	2	2	2	2	2	2	2	2	2	2	2	2	2	2	2	2	
446	M9 1602 001	W500036	頭ナシ止メネジ 1/4(40)×4	Ball bearing set screw	1	1	1	1	1	1	1	1	1	1	1	1	1	1	1	1	1	1	
447	M9 1603 001	W468269	トメネジ棒サキ 1/4(40)×5	Ball bearing set screw	1	1	1	1	1	1	1	1	1	1	1	1	1	1	1	1	1	1	
448	MN 10E0 456	W462945G01	球 軸 受 ケ	Ball bearing(for lower shaft)	1	1	1	1	1	1	1	1	1	1	1	1	1	1	1	1	1	1	
449	MN 10A0 771	W461041	球 軸 受 ケ 押 エ	Ball bearing(for lower shaft)presser	1	1	1	1	1	1	1	1	1	1	1	1	1	1	1	1	1	1	

DU-105/115/125形 返し縫い機構部分  
 REVERSE SEWING MOTION MECHANISM

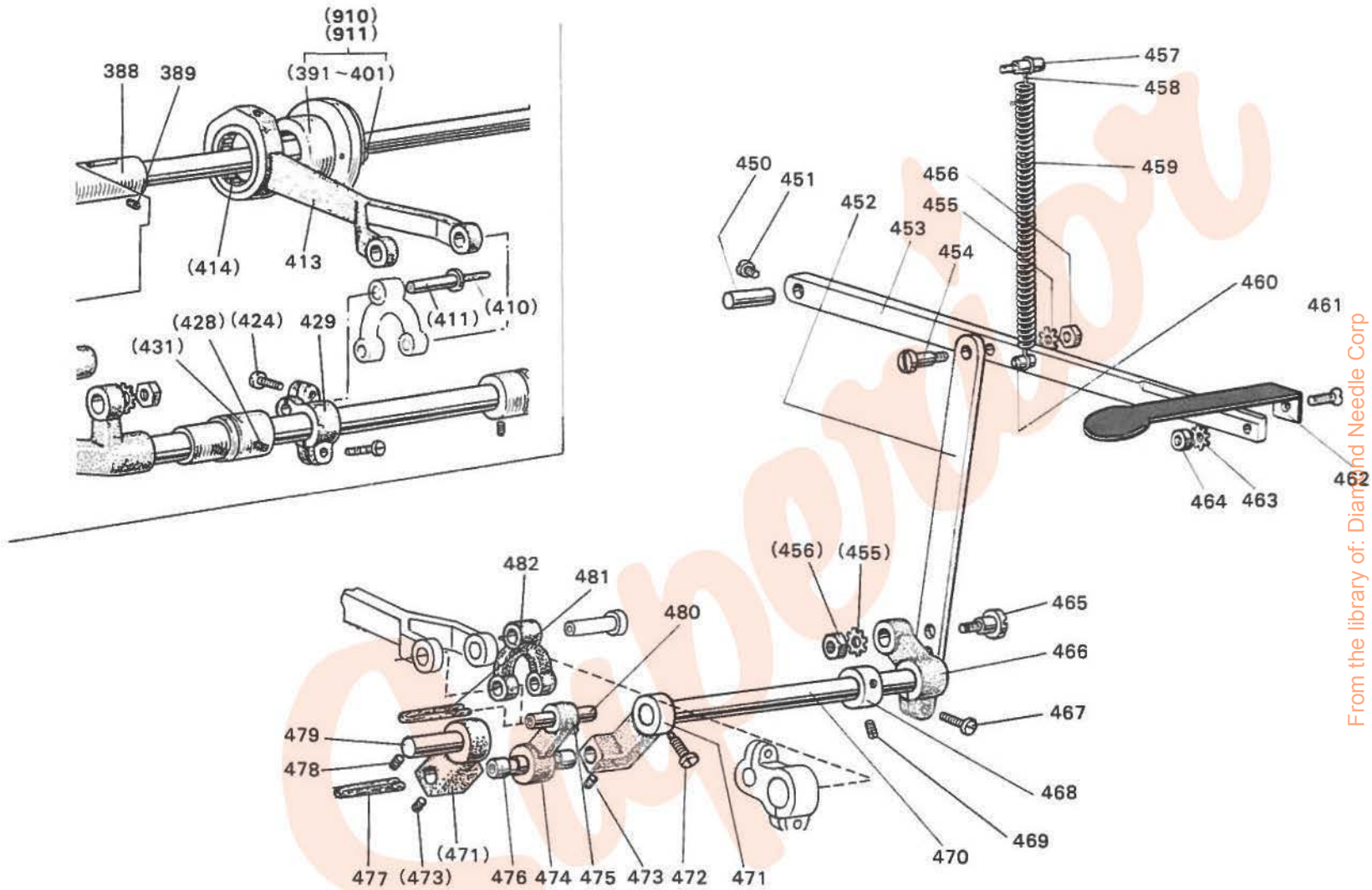

From the library of: Diamond Needle Corp



## DU-105/115/125形 返し縫い機構部分

## REVERSE SEWING MOTION MECHANISM

Fig. No.	サービス部品コード Part No.	資材コード Code No.	部 品 名	Name of Part	個 / 台 Amt. req.												備 考 Remarks						
					DU 100	DU 110	DU 120	DU 105	DU 115	DU 125	DU 103	DU 113	DU 123	DU 108	DU 118	DU 128		DU 102	DU 112	DU 122	DU 107	DU 117	DU 127
450	M9 0604 060	W502791	ピン 6.35φ×20	Pin						1	1	1											
451	M9 0903 002	B 509065	平ネジ 9/64(40)×6.5	Screw						1	1	1			1	1	1				1	1	1
452	MN 15A0 953	W462951	連結板	Reverse lever connecting plate						1	1	1			1	1	1						
453	MN 15A0 322	W459354	返し縫イテコ	Reverse stitch lever						1	1	1			1	1	1						
454	M9 1506 015	W501246	段付平ネジ 15/64(28)×16	Screw						1	1	1			1	1	1						
455	M9 0601 051	W462950	歯付座金 B6	Lock washer						2	2	2			2	2	2				2	2	2
456	M9 1501 045	W501883	ナット 15/64(28)×4	Nut						2	2	2			2	2	2				2	2	2
457	M9 0302 063	W502343	バネ案内ピン 3φ×10.3	Spring guide pin						1	1	1			1	1	1						
458	MN 15A0 708	W502928	バネカケ金	Spring guide pin bracket						2	2	2			2	2	2				2	2	2
459	MN 15A0 572	W461028	ツル巻キバネ	Spring						1	1	1			1	1	1				1	1	1
460	M9 1101 030	W502032	バネカケピン	Spring guide pin						1	1	1			1	1	1				1	1	1
461	M9 1201 010	W501934	皿ネジ 3/16(28)×10	Screw						1	1	1			1	1	1				1	1	1
462	MN 15A0 321	W459355	返し縫イ板	Reverse stitch lever plate						1	1	1			1	1	1				1	1	1
463	M9 0501 051	W462760	歯付座金 B5	Lock washer						1	1	1			1	1	1				1	1	1
464	M9 1202 045	W500001	ナット 3/16(28)×4	Nut						1	1	1			1	1	1				1	1	1
465	M9 1502 016	W501570	段付丸平ネジ 15/64(28)×18	Connecting plate set screw						1	1	1			1	1	1				1	1	1
466	MN 15A0 324	W502924	返し縫イ腕(右)	Reverse stitch shaft crank(right)						1	1	1			1	1	1				1	1	1
467	M9 1117 002	B 503844	平ネジ 11/64(40)×13	Reverse stitch shaft(right)set screw						1	1	1			1	1	1				1	1	1
468	MM 11A0 352	W446142	カラール	Reverse stitch shaft collar						1	1	1			1	1	1				1	1	1
469	M9 1506 001	B 509087	頭ナシ止メネジ 15/64(28)×7	Reverse stitch shaft collar set screw						2	2	2			2	2	2				2	2	2
470	MP 05B0 320	W461052	返し縫イ軸	Reverse stitch shaft						1	1	1			1	1	1				1	1	1
471	MN 15A0 323	W461018	返し縫イ腕	Reverse stitch shaft crank(left)						2	2	2			2	2	2				2	2	2
472	M9 1501 007	B 509256	標先平ネジ 15/64(28)×14.5	Set screw						1	1	1			1	1	1				1	1	1
473	M9 1106 001	B 509266	頭ナシ止メネジ 11/64(40)×4.3	Screw(for Fig.476)						2	2	2			2	2	2				2	2	2
474	MN 15A0 886	W460582	揺動腕	Bell crank						1	1	1			1	1	1				1	1	1
475	M9 1202 001	W500151	頭ナシ止メネジ 3/16(28)×6	Bell crank set screw						1	1	1			1	1	1				1	1	1
476	M9 0702 060	W460583	ピン 7.94φ×63	Pin						1	1	1			1	1	1				1	1	1
477	MF 10E2 148	W462729	油ヒモ 2.5×125	Oil wick						1	1	1			1	1	1				1	1	1
478	M9 1653 001	W500478	頭ナシ止メネジ 1/4(24)×8	Set screw						1	1	1			1	1	1				1	1	1
479	M9 0906 063	W461020	ピン 9.53φ×30	Pin						1	1	1			1	1	1				1	1	1
480	M9 0703 060	W502921	ピン 7.94φ×29	Pin						1	1	1			1	1	1				1	1	1
481	MF 10E2 148	W462981	油ヒモ 2.5φ×60	Oil wick						1	1	1			1	1	1				1	1	1
482	MN 15A0 910	W460584	リンク	Connecting link						1	1	1			1	1	1				1	1	1
483	M9 0902 011	W500994	丸皿ネジ 9/64(40)×7(23頁参照)							3	3	3			3	3	3				3	3	3

DU-100形 給油機構部分 OIL LUBRICATION MECHANISM

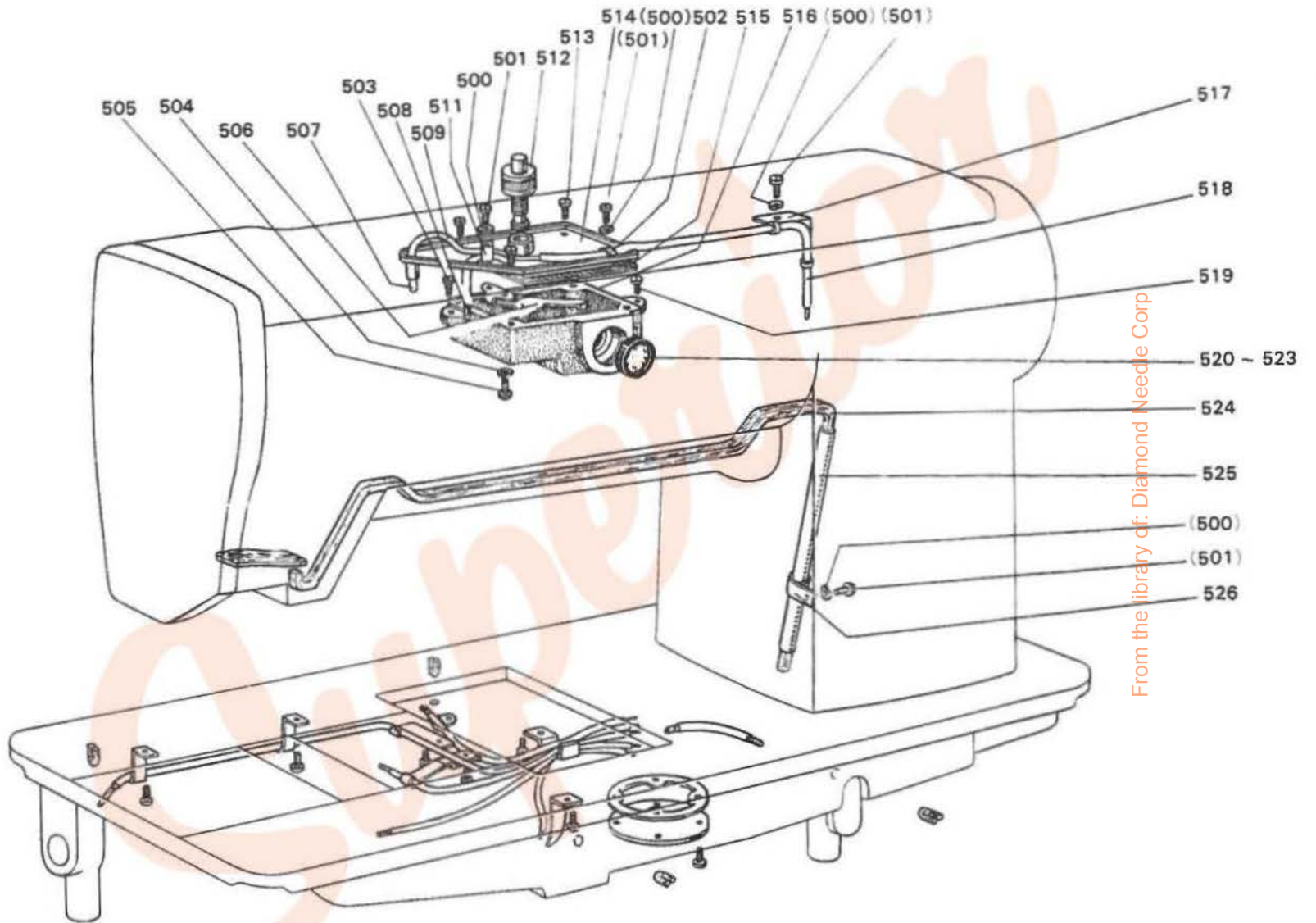

From the library of: Diamond Needle Corp



DU-100形 給油機構部分

OIL LUBRICATION MECHANISM

Fig. No.	サービス部品コード Part No.	資材コード Code No.	部 品 名	Name of Part	個 / 台 Amt. req												備 考 Remarks						
					DU-100	DU-110	DU-120	DU-105	DU-115	DU-125	DU-103	DU-113	DU-123	DU-108	DU-118	DU-128		DU-102	DU-112	DU-122	DU-107	DU-117	DU-127
500	M9 0302 053	W462953	バネ座金 3.5	Oil pipe holder washer	4	4	4	4	4	4	4	4	4	4	4	4	4	4	4	4	4	4	
501	M9 0903 002	B 509065	平ネジ 9/64(40)×6.5	Oil pipe holder screw	4	4	4	4	4	4	4	4	4	4	4	4	4	4	4	4	4	4	
502	MF 10A0 689	W444230	パイプホルダー	Oil pipe holder	1	1	1	1	1	1	1	1	1	1	1	1	1	1	1	1	1	1	
503	M9 0924 002	B 509068	平ネジ 9/64(40)×10	Oil resevoir set screw	1	1	1	1	1	1	1	1	1	1	1	1	1	1	1	1	1	1	
504	M9 0804 002	B 503897	平ネジ 1/8(44)×3.5	Oil resevoir set screw	2	2	2	2	2	2	2	2	2	2	2	2	2	2	2	2	2	2	
505	M9 0301 053	W461769	バネ座金 3	Oil resevoir washer for set screw	2	2	2	2	2	2	2	2	2	2	2	2	2	2	2	2	2	2	
506	MN 10A1 192	W446556	板バネ	Oil pipe holder spring plate	1	1	1	1	1	1	1	1	1	1	1	1	1	1	1	1	1	1	
507	MF 10E2 148	W462982	油ヒモ 2.5φ×330	Oil wick	1	1	1	1	1	1	1	1	1	1	1	1	1	1	1	1	1	1	
508	MN 10A5 740	W462954	フェルト	Felt	1	1	1	1	1	1	1	1	1	1	1	1	1	1	1	1	1	1	
509	MP 00B0 731	W462993	ビニールパイプ	Oil pipe(vinyl)	1	1	1	1	1	1	1	1	1	1	1	1	1	1	1	1	1	1	
510	MF 10E2 148	W462729	油ヒモ 2.5φ×125	Oil wick	1	1	1	1	1	1	1	1	1	1	1	1	1	1	1	1	1	1	
511	MN 10A0 689	W501220	パイプホルダー	Oil pipe holder	1	1	1	1	1	1	1	1	1	1	1	1	1	1	1	1	1	1	
512	MN 10A0 528	W462955	ダンナー	Oil control plunger	1	1	1	1	1	1	1	1	1	1	1	1	1	1	1	1	1	1	
513	M9 0903 002	B 509065	平ネジ 9/64(40)×6.5	Oil resevoir cover set screw	3	3	3	3	3	3	3	3	3	3	3	3	3	3	3	3	3	3	
514	MP 00B0 742	W326231	フタ板	Oil resevoir cover	1	1	1	1	1	1	1	1	1	1	1	1	1	1	1	1	1	1	
515	MN 10A2 697	W444116	パッキン	Oil resevoir gasket	1	1	1	1	1	1	1	1	1	1	1	1	1	1	1	1	1	1	
516	MN 10A0 139	W444114	油タンク	Oil resevoir	1	1	1	1	1	1	1	1	1	1	1	1	1	1	1	1	1	1	
517	MN 25A1 689	W446499	パイプホルダー	Oil pipe holder	1	1	1	1	1	1	1	1	1	1	1	1	1	1	1	1	1	1	
518	MN 10A0 731	W462994	ビニールパイプ	Oil pipe(vinyl)	1	1	1	1	1	1	1	1	1	1	1	1	1	1	1	1	1	1	
519	M9 0924 002	B 509068	平ネジ 9/64(40)×10	Oil resevoir set screw	1	1	1	1	1	1	1	1	1	1	1	1	1	1	1	1	1	1	
520	MP 00B0 691	W500266	パッキン	Oil indicator packing	2	2	2	2	2	2	2	2	2	2	2	2	2	2	2	2	2	2	
521	MN 25A0 841	W500267	目盛板	Oil indicator plate	1	1	1	1	1	1	1	1	1	1	1	1	1	1	1	1	1	1	
522	MN 25A0 135	W500265	油窓	Oil indicator	1	1	1	1	1	1	1	1	1	1	1	1	1	1	1	1	1	1	
523	M9 7601 047	W444115	リングナット 1 3/8×4.5	Oil indicator ring nut	1	1	1	1	1	1	1	1	1	1	1	1	1	1	1	1	1	1	
524	MN 25A1 740	W462956	フェルト	Felt	1	1	1	1	1	1	1	1	1	1	1	1	1	1	1	1	1	1	
525	MN 10A1 731	W462995	ビニールパイプ	Oil pipe(vinyl)	1	1	1	1	1	1	1	1	1	1	1	1	1	1	1	1	1	1	
526	MN 10A1 689	W501202	パイプホルダー	Oil pipe holder	1	1	1	1	1	1	1	1	1	1	1	1	1	1	1	1	1	1	

DU-100形 給油機構部分 OIL LUBRICATION MECHANISM

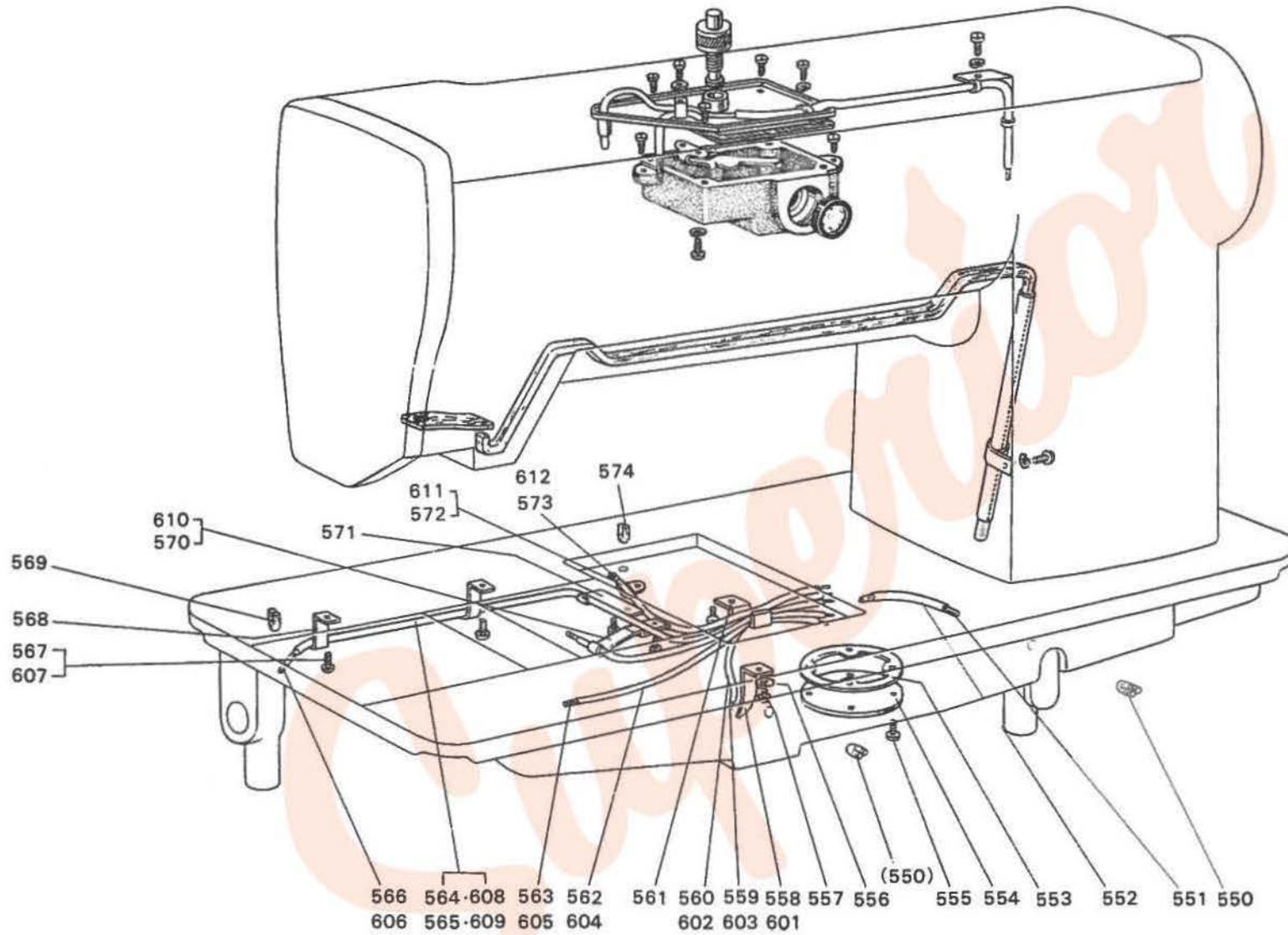

From the library of: Diamond Needle Corp



DU-100形 給油機構部分

OIL LUBRICATION MECHANISM

Fig. No.	サービス部品コード Part No.	資材コード Code No.	部 品 名	Name of Part	個 / 合 Amt. req													備 考 Remarks						
					DU-100	DU-110	DU-120	DU-105	DU-115	DU-125	DU-103	DU-113	DU-123	DU-108	DU-118	DU-128	DU-102		DU-112	DU-122	DU-107	DU-117	DU-127	
550	MF 10E2 148	W462983	油 ヒ モ 2.5φ×50	Oil wick	2	2	2	2	2	2	2	2	2	2	2	2	2	2	2	2	2	2	2	
551	MF 10E2 148	W462984	油 ヒ モ 2.5φ×150	Oil wick	1	1	1	1	1	1	1	1	1	1	1	1	1	1	1	1	1	1	1	
552	MN 10A2 731	W462996	ビニールパイプ	Oil pipe(vinyl)	1	1	1	1	1	1	1	1	1	1	1	1	1	1	1	1	1	1	1	
553	MN 10A1 691	W444122	パ ッ キ ン	Gasket	1	1	1	1	1	1	1	1	1	1	1	1	1	1	1	1	1	1	1	
554	MN 10A3 742	W444237	フ タ	Oil resevoir cover	1	1	1	1	1	1	1	1	1	1	1	1	1	1	1	1	1	1	1	
555	M9 1117 002	B 503844	平 ネ ジ 11 64(40)×13	Oil resevoir cover set screw	4	4	4	4	4	4	4	4	4	4	4	4	4	4	4	4	4	4	4	
556	M9 0302 053	W462953	パ ネ 座 金 3.5	Oil pipe holder set washer	5	5	5	5	5	5	5	5	5	5	5	5	5	5	5	5	5	5	5	
557	M9 0903 002	B 509065	平 ネ ジ 9 64(40)×6.5	Oil pipe holder set screw	5	5	5	5	5	5	5	5	5	5	5	5	5	5	5	5	5	5	5	
558	MF 65B0 689	W501200	パイプホルダー	Oil pipe holder	1	1	1			1	1	1										1	1	
559	MF 10E3 148	W462830	油 ヒ モ 3φ×180	Oil wick	1	1	1			1	1	1									1	1	1	
560	MN 10A3 731	W462997	ビニールパイプ	Oil pipe(vinyl)	1	1	1			1	1	1									1	1	1	
561	MN 25A0 689	W453595	パイプホルダー	Oil pipe holder	1	1	1	1	1	1	1	1	1	1	1	1	1	1	1	1	1	1	1	
562	MN 10A4 731	W462998	ビニールパイプ 3.5φ×5.2φ×320	Oil pipe(vinyl)	2	2	2			2	2	2									2	2	2	
563	MF 10E2 148	W462985	油 ヒ モ 2.5φ×220	Oil wick	2	2	2			2	2	2									2	2	2	
564	MN 10A5 731	W462999	ビニールパイプ	Oil pipe(vinyl)	1	1				1	1										1	1		
565	MP 03B0 731	W464000	ビニールパイプ 3.5φ×5.2φ×320	Oil pipe(vinyl)		1				1												1		
566	MF 10E2 148	W462986	油 ヒ モ 2.5φ×470	Oil wick	1	1	1			1	1										1	1	1	
567	MF 10E2 148	W462987	油 ヒ モ 2.5φ450	Oil wick		1				1												1		
568	MN 10A4 689	W446255	パイプホルダー	Oil pipe holder	2	2	2	2	2	2	2	2	2	2	2	2	2	2	2	2	2	2	2	
569	MF 10E2 148	W462979	油 ヒ モ 2.5φ×80	Oil wick	1	1	1	1	1	1	1	1	1	1	1	1	1	1	1	1	1	1	1	
570	MN 10A7 689	W453596	パイプホルダー	Oil pipe holder	1	1	1			1	1										1		1	
571	MN 10A3 689	W446254	パイプホルダー	Oil pipe holder	1	1	1			1	1										1	1	1	
572	MN 10A6 731	W464001	ビニールパイプ 3.5φ×5.2φ×60	Oil pipe(vinyl)	1	1	1			1	1										1	1	1	
573	MF 10E3 148	W462830	油 ヒ モ 3φ×180	Oil wick	1	1	1			1	1										1	1	1	
574	MF 10E2 148	W462983	油 ヒ モ 2.5φ×50	Oil wick	1	1	1	1	1	1	1	1	1	1	1	1	1	1	1	1	1	1	1	
601	MF 15A0 689	W501201	パイプホルダー	Oil pipe holder				1	1	1				1	1	1						1	1	
602	MN 15A4 731	W464051	ビニールパイプ 3.5φ×5.2φ×130	Oil pipe(vinyl)				1	1	1				1	1	1						1	1	
603	MF 10E2 148	W444138	油 ヒ モ 2.5×240	Oil wick				1	1	1				1	1	1						1	1	
604	MN 15A0 731	W464002	ビニールパイプ 3.5φ×5.2φ×200	Oil pipe(vinyl)				1	1	1				1	1	1						1	1	
605	MF 10E2 148	W462988	油 ヒ モ 2.5×300	Oil wick				1	1	1				1	1	1						1	1	
606	MF 10E2 148	W462989	油 ヒ モ 2.5×620	Oil wick				1	1					1	1							1	1	
607	MF 10E2 148	W462986	油 ヒ モ 2.5×470	Oil wick				1	1					1	1							1	1	
608	MN 15A1 731	W464003	ビニールパイプ 3.5φ×5.2φ×415	Oil pipe(vinyl)				1	1					1	1							1	1	
609	MN 10A5 731	W462999	ビニールパイプ	Oil pipe(vinyl)				1						1								1		
610	MF 10A0 689	W444230	パイプホルダー	Oil pipe holder				1	1	1				1	1	1						1	1	
611	MN 15A3 731	W464006	ビニールパイプ 3.5φ×5.2φ×210	Oil pipe(vinyl)				1	1					1	1	1						1	1	
612	MF 10E2 148	W462992	油 ヒ モ 2.5φ×320	Oil wick				1	1	1				1	1	1						1	1	

DUクラス ゲージ部品の組合せ GAUGE PARTS & ITS COMPLEMENT

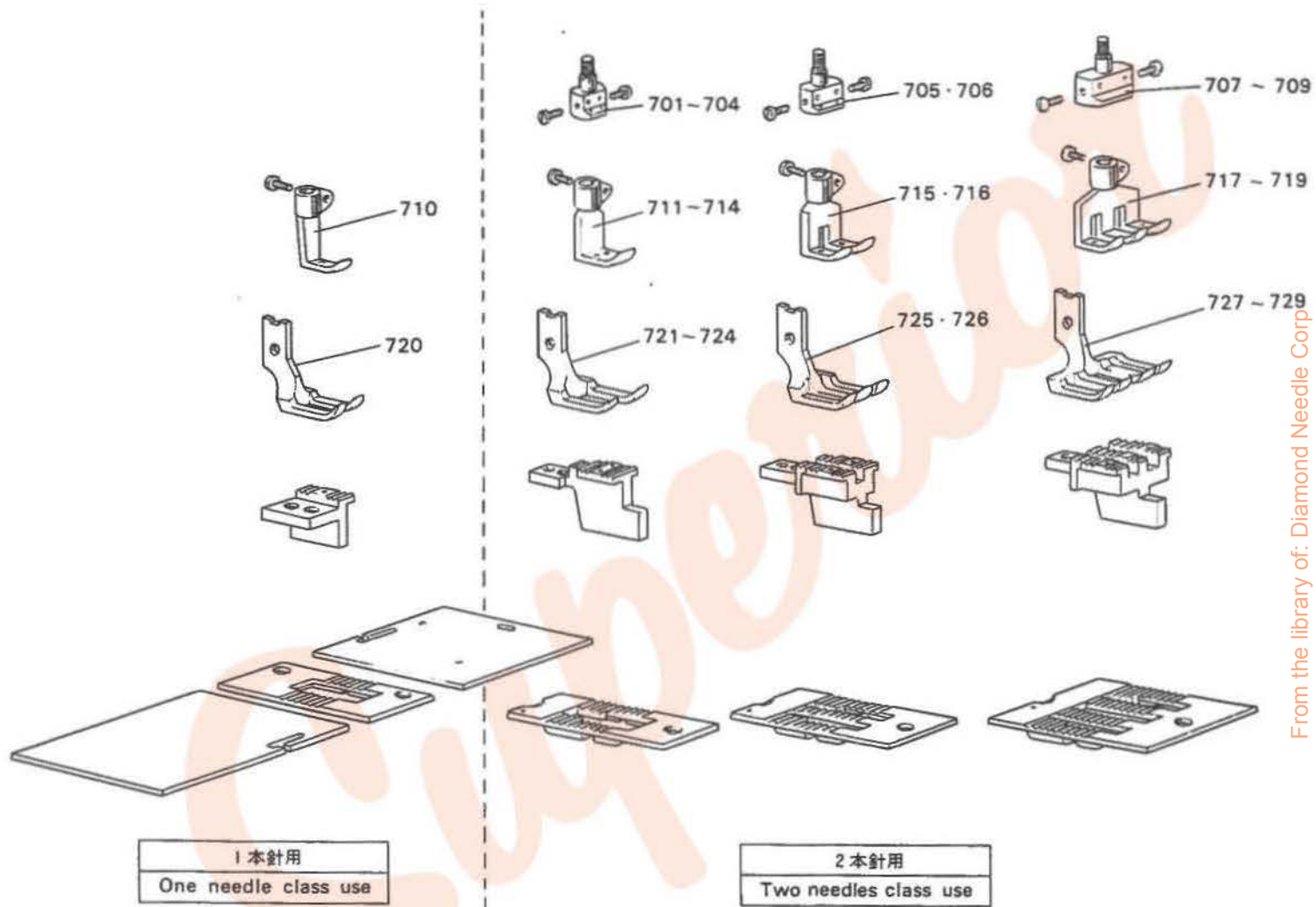

From the library of: Diamond Needle Corp



DUクラス ゲージ部品の組合せ

GAUGE PARTS & ITS COMPLEMENT

Fig. No.	サービス部品コード Part No.	資材コード Code No.	部 品 名	Name of Part	個 / 合 Amt req												備 考 Remarks									
					DU-100	DU-110	DU-120	DU-105	DU-115	DU-125	DU-103	DU-113	DU-123	DU-108	DU-118	DU-128		DU-102	DU-112	DU-122	DU-107	DU-117	DU-127			
701	MP 20J5 102	W462959	針 ダ キ 5/32	Needle clamp																						
702	MP 20J4 102	W468535	針 ダ キ 1/8	Needle clamp																						
703	MP 20J8 102	W457557	針 ダ キ 1/4	Needle clamp																						
704	MP 20J9 102	W466841	針 ダ キ 5/16	Needle clamp																						
705	MP 20K1 102	W462962	針 ダ キ 3/8	Needle clamp																						
706	MP 20K3 102	W462963	針 ダ キ 1/2	Needle clamp																						
707	MP 20K4 102	W462964	針 ダ キ 5/8	Needle clamp																						
708	MP 20K5 102	W462969	針 ダ キ 3/4	Needle clamp																						
709	MP 20K6 102	W462970	針 ダ キ 1	Needle clamp																						
710	MP 00B0 107	W462957	内 押 エ	Presser foot(inside)																						
711	MP 20J5 107	W462960	内 押 エ 5/32	Presser foot(inside)																						
712	MP 20J4 107	W468536	内 押 エ 1/8	Presser foot(inside)																						
713	MP 20J8 107	W457562	内 押 エ 1/4	Presser foot(inside)																						
714	MP 20J9 107	W466839	内 押 エ 5/16	Presser foot(inside)																						
715	MP 20K1 107	W457559	内 押 エ 3/8	Presser foot(inside)																						
716	MP 20K3 107	W462965	内 押 エ 1/2	Presser foot(inside)																						
717	MP 20K4 107	W462966	内 押 エ 5/8	Presser foot(inside)																						
718	MP 20K5 107	W461030	内 押 エ 3/4	Presser foot(inside)																						
719	MP 20K6 107	W461971	内 押 エ 1	Presser foot(inside)																						
720	MP 00B0 106	W462958	外 押 エ	Presser foot(out side)																						
721	MP 20J5 106	W462961	外 押 エ 5/32	Presser foot(out side)																						
722	MP 20J4 106	W468537	外 押 エ 1/8	Presser foot(out side)																						
723	MP 20J8 106	W457563	外 押 エ 1/4	Presser foot(out side)																						
724	MP 20J9 106	W466840	外 押 エ 5/16	Presser foot(out side)																						
725	MP 20K1 106	W457560	外 押 エ 3/8	Presser foot(out side)																						
726	MP 20K3 106	W462967	外 押 エ 1/2	Presser foot(out side)																						
727	MP 20K4 106	W462968	外 押 エ 5/8	Presser foot(out side)																						
728	MP 20K5 106	W461033	外 押 エ 3/4	Presser foot(out side)																						
729	MP 20K6 106	W462972	外 押 エ 1	Presser foot(out side)																						

From the library of Diamond Needle Corp

DUクラス ゲージ部品の組合せ GAUGE PARTS & ITS COMPLEMENT

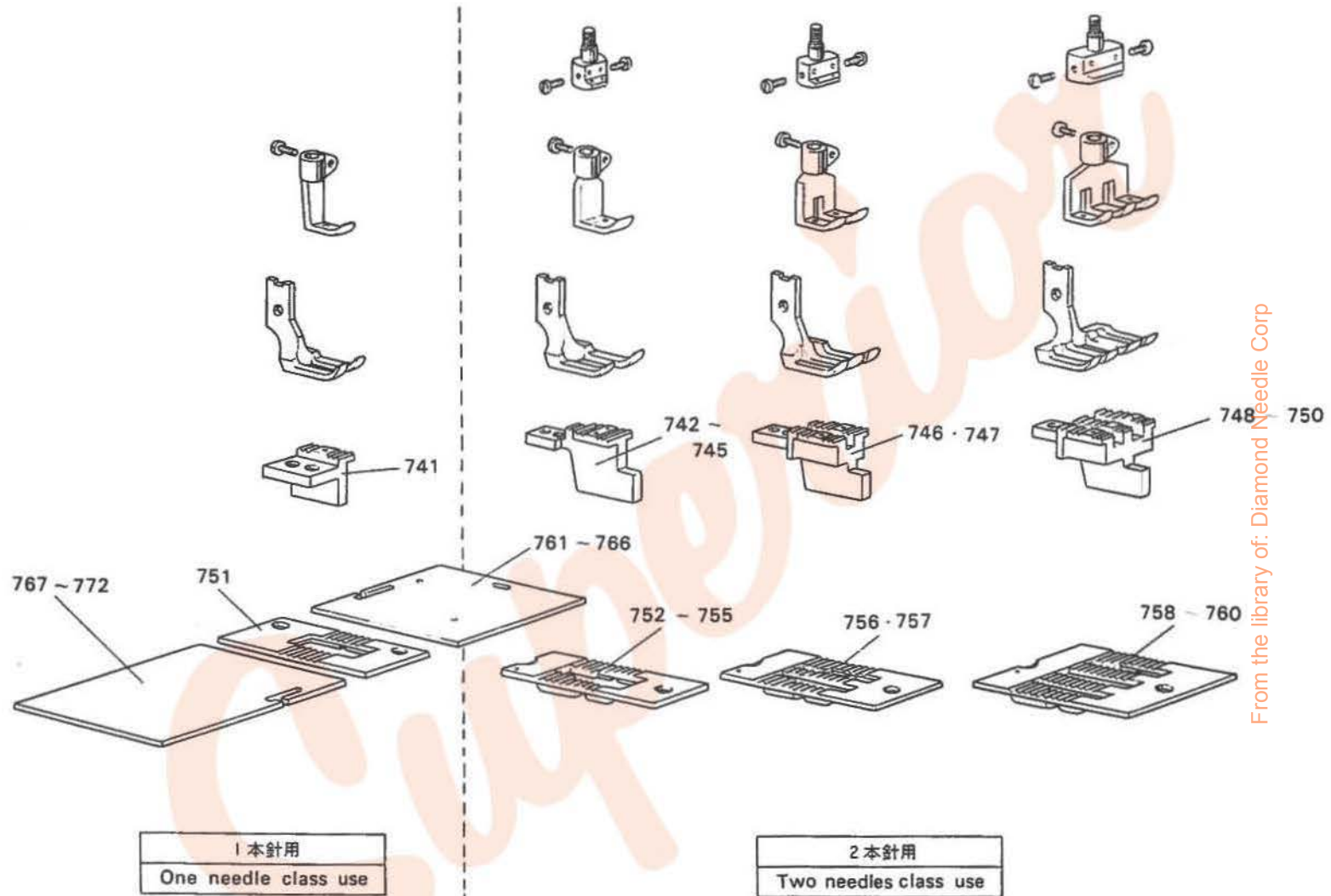

From the library of: Diamond Needle Corp



DUクラス ゲージ部品の組合せ

GAUGE PARTS & ITS COMPLEMENT

Fig No.	サービス部品コード Part No.	資材コード Code No.	部 品 名	Name of Part	個 / 台 Amt req												備 考 Remarks					
					DU 100	DU 110	DU 120	DU 105	DU 115	DU 125	DU 103	DU 113	DU 123	DU 108	DU 118	DU 128		DU 102	DU 112	DU 122	DU 107	DU 117
741	MP 20B0 104	W453592	送り	Feed dog	①	①	①	①	①	①	①	①	①	①	①	①	①	①	①	①	①	
742	MP 20J5 104	W326232	送り 5/32	Feed dog		①		①		①		①		①		①		①		①		
743	MP 20J4 104	W330138	送り 1/8	Feed dog		①		①		①		①		①		①		①		①		
744	MP 20J8 104	W324560	送り 1/4	Feed dog		①		①		①		①		①		①		①		①		
745	MP 20J9 104	W327697	送り 5/16	Feed dog		①		①		①		①		①		①		①		①		
746	MP 20K1 104	W326234	送り 3/8	Feed dog		①		①		①		①		①		①		①		①		
747	MP 20K3 104	W326235	送り 1/2	Feed dog		①		①		①		①		①		①		①		①		
748	MP 20K4 104	W324558	送り 5/8	Feed dog		①		①		①		①		①		①		①		①		
749	MP 20K5 104	W326238	送り 3/4	Feed dog		①		①		①		①		①		①		①		①		
750	MP 20K6 104	W324556	送り 1"	Feed dog		①		①		①		①		①		①		①		①		
751	MP 00B0 101	W453598	針 板	Needle plate	①	①	①	①	①	①	①	①	①	①	①	①	①	①	①	①	①	
752	MP 20J5 101	W326233	針 板 5/32	Needle plate		①		①		①		①		①		①		①		①		
753	MP 20J4 101	W330137	針 板 1/8	Needle plate		①		①		①		①		①		①		①		①		
754	MP 20J8 101	W324559	針 板 1/4	Needle plate		①		①		①		①		①		①		①		①		
755	MP 20J9 101	W327696	針 板 5/16	Needle plate		①		①		①		①		①		①		①		①		
756	MP 20K1 101	W326236	針 板 3/8	Needle plate		①		①		①		①		①		①		①		①		
757	MP 20K3 101	W326237	針 板 1/2	Needle plate		①		①		①		①		①		①		①		①		
758	MP 20K4 101	W324557	針 板 5/8	Needle plate		①		①		①		①		①		①		①		①		
759	MP 20K5 101	W326239	針 板 3/4	Needle plate		①		①		①		①		①		①		①		①		
760	MP 20K6 101	W324555	針 板 1"	Needle plate		①		①		①		①		①		①		①		①		
761	MP 00B0 474	W454866	スベリ板(右)	Slide plate(right)	①		①		①		①		①		①		①		①		①	
762	MP 10B0 474	W462973	スベリ板(右)	Slide plate(right)		①		①		①		①		①		①		①		①		
763	MP 10A0 474	W445916	スベリ板(右) 5/32,1/8,1/4用	Slide plate(right)		①		①		①		①		①		①		①		①		
764	MP 20B0 474	W462974	スベリ板(右) 5/16,3/8用	Slide plate(right)		①		①		①		①		①		①		①		①		
765	MP 20B1 474	W447188	スベリ板(右) 1/2,5/8,3/4用	Slide plate(right)		①		①		①		①		①		①		①		①		
766	MP 20B2 474	W448309	スベリ板(右) 1用	Slide plate(right)		①		①		①		①		①		①		①		①		
767	MP 10B0 473	W462975	スベリ板(左)	Slide plate(left)		①		①		①		①		①		①		①		①		
768	MP 10A0 473	W445915	スベリ板(左) 5/32,1/8	Slide plate(left)		①		①		①		①		①		①		①		①		
769	MP 20B1 473	W462976	スベリ板(左) 5/16,3/8,1/4	Slide plate(left)		①		①		①		①		①		①		①		①		
770	MP 00B0 473	W447187	スベリ板(左) 1/2,5/8	Slide plate(left)	①	①	①	①	①	①	①	①	①	①	①	①	①	①	①	①	①	
771	MP 20B3 473	W448308	スベリ板(左) 1	Slide plate(left)		①		①		①		①		①		①		①		①		
772	MP 20B2 473	W462977	スベリ板(左) 3/4	Slide plate(left)		①		①		①		①		①		①		①		①		

from the library of: Diamond Needle Corp

DU-100形 付属品 ACCESSORIES

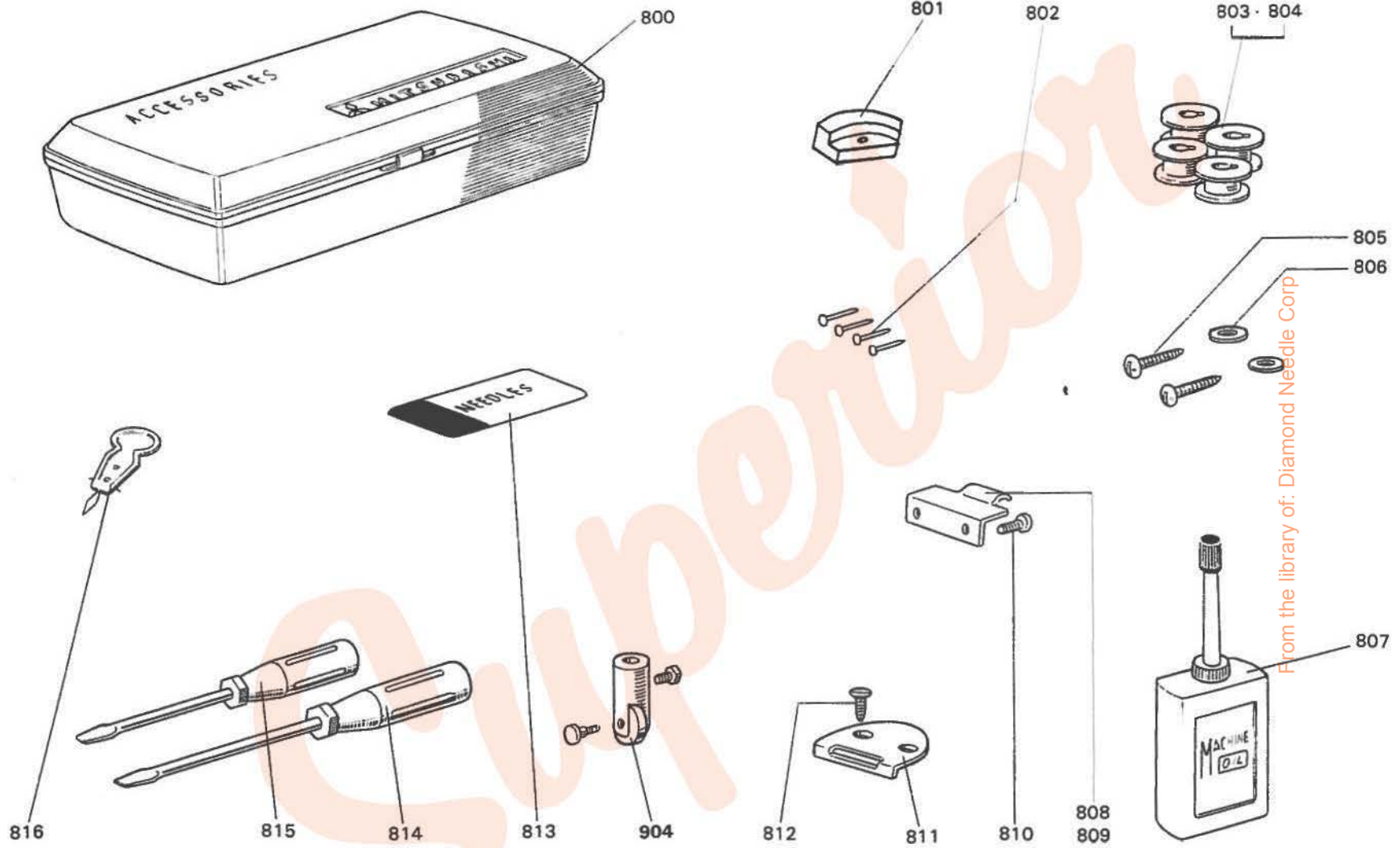



DU-100形 付属品  
ACCESSORIES

Fig No.	サービス部品コード Part No.	資材コード Code No.	部 品 名	Name of Part	個 / 台 Amt req													備 考 Remarks						
					DU 100	DU 110	DU 120	DU 105	DU 115	DU 125	DU 103	DU 113	DU 123	DU 108	DU 118	DU 128	DU 102		DU 112	DU 122	DU 107	DU 117	DU 127	
800	MF 36A0 749	W450684	付 属 品 箱	Accessory box	1	1	1	1	1	1	1	1	1	1	1	1	1	1	1	1	1	1	1	
801	MF 60A0 419	W449461	防 振 ゴ ム	Vibration preventing rubber	4	4	4	4	4	4	4	4	4	4	4	4	4	4	4	4	4	4	4	
802		W990003	釘(8分釘)(防振ゴム緩用)	Nail	9	9	9	9	9	9	9	9	9	9	9	9	9	9	9	9	9	9	9	
803	MN 10A0 123	W445964	ボ ビ ン	Bobbin	4	4	8	4	4	8														
	MN 12B0 123	W462929	ボ ビ ン	Bobbin																				
804	MP 03B0 123	W462928	ボ ビ ン 144形	Bobbin							2	2	4	2	2	4								
805	M9 0401 041	W990010	丸 木 ネ ジ 4.5×20	Screw	2	2	2	2	2	2	2	2	2	2	2	2	2	2	2	2	2	2	2	
806	M9 0608 050	W990011	座 金 6	Washer	2	2	2	2	2	2	2	2	2	2	2	2	2	2	2	2	2	2	2	
807			油 差 シ	Oil with oiler	1	1	1	1	1	1	1	1	1	1	1	1	1	1	1	1	1	1	1	
808	MF 60A0 562	W502124	蝶 番 棒	Hinge hook		2		2		2		2		2		2		2		2		2		
809	MN 10A0 561	W445507	蝶 番 (1)	Hinge(1)	2	2	2	2	2	2	2	2	2	2	2	2	2	2	2	2	2	2	2	
810	M9 1602 003	W461766	丸 平 ネ ジ 1/4(24)×13	Hinge(1)set screw	4	4	4	4	4	4	4	4	4	4	4	4	4	4	4	4	4	4	4	
811	MN 10A0 561	W445508	蝶 番 (2)	Hinge(2)	2	2	2	2	2	2	2	2	2	2	2	2	2	2	2	2	2	2	2	
812	M9 0501 040	W990012	皿 木 ネ ジ 5.5×25	Hinge(2)set screw	4	4	4	4	4	4	4	4	4	4	4	4	4	4	4	4	4	4	4	
904	MN 10E0 970	W462918	ロ ー ラ ー(組)	Roller complete	1	1	1	1	1	1	1	1	1	1	1	1	1	1	1	1	1	1	1	
813			針 DP×17#23	Needle	4	4	6	4	6	4	6	4	6	4	6	4	6	4	6	4	6	4	6	
814	MB 02A1 608	P 842003X01	ネ ジ 回 シ(中)	Screw driver(middle)	1	1	1	1	1	1	1	1	1	1	1	1	1	1	1	1	1	1	1	
815	MB 02A0 608	P 842002X01	ネ ジ 回 シ(小) Fig.No.814ニ含ム	Screw driver(small)	1	1	1	1	1	1	1	1	1	1	1	1	1	1	1	1	1	1	1	
816			糸 通 シ 器	Thread a needle kit	1	1	1	1	1	1	1	1	1	1	1	1	1	1	1	1	1	1	1	

From the library of: Diamant-Prague

DU-100形 付属品 ACCESSORIES

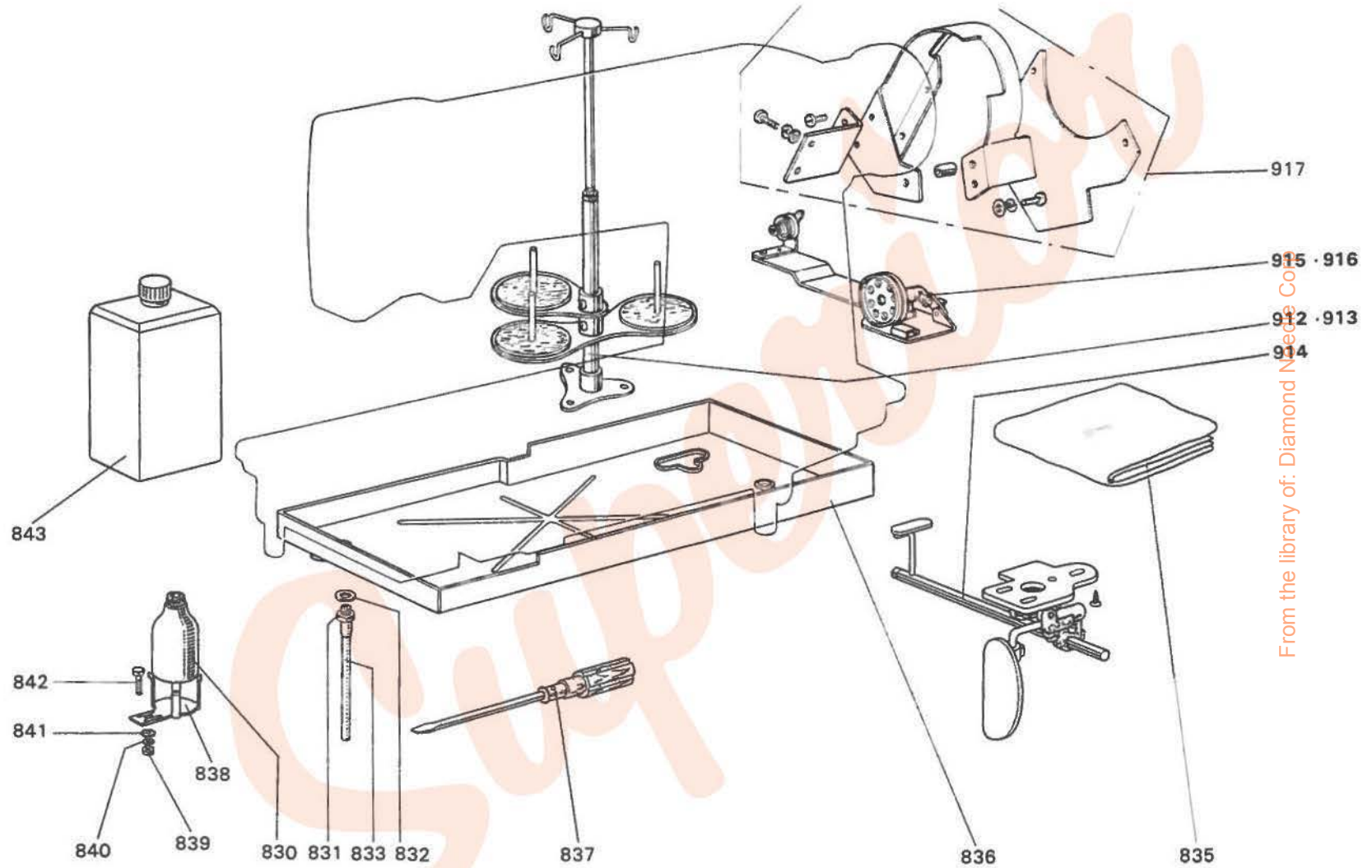

From the library of: Diamond Nece Co



**DU-100形 付属品 ACCESSORIES**

Fig. No.	サービス部品コード Part No.	資材コード Code No.	部 品 名	Name of Part	個 / 台 Amt. req													備 考 Remarks				
					DU-100	DU-110	DU-120	DU-105	DU-115	DU-125	DU-103	DU-113	DU-123	DU-108	DU-118	DU-128	DU-102		DU-112	DU-122	DU-107	DU-117
912	MN 10E0 193	W218874	糸 立 仕 掛	Cotton stand	1	1	1	1	1	1	1	1	1	1	1	1	1	1	1	1		
913	MP 20E0 193	SM35205	糸 立 仕 掛	Cotton stand		1		1		1		1		1		1		1		1		
830	MF 20A0 130	W319422	油 ビ ン	Oil bottle	1	1	1	1	1	1	1	1	1	1	1	1	1	1	1	1	1	1
831	M9 2001 047	W446050	ネジブッシュ 5/16(28)×29	Screw bush	1	1	1	1	1	1	1	1	1	1	1	1	1	1	1	1	1	1
832	MF 10A4 691	W500812	パ ッ キ ン	Packing	1	1	1	1	1	1	1	1	1	1	1	1	1	1	1	1	1	1
833	MF 36A0 731	W451152	パ イ プ	Vinyl pipe	1	1	1	1	1	1	1	1	1	1	1	1	1	1	1	1	1	1
914	MP 00E0 727	SM31038	ヒザ上げ仕掛(組)	Knee lifter complete	1	1	1	1	1	1	1	1	1	1	1	1	1	1	1	1	1	1
915	MF 20E0 190	SM31097	糸 巻 仕 掛	Bobbin winder	1	1	1	1	1	1												
916	MP 03E0 190		糸 巻 仕 掛	Bobbin winder						1	1	1	1	1	1	1	1	1	1	1	1	1
835		W220627	ビニールカバー	Vinyl cover	1	1	1	1	1	1	1	1	1	1	1	1	1	1	1	1	1	1
836	MN 10A1 131	W220638	油 受	Oil resevoir	1	1	1	1	1	1	1	1	1	1	1	1	1	1	1	1	1	1
837		W20435-A	ネジ回シ大	Screw driver(large)	1	1	1	1	1	1	1	1	1	1	1	1	1	1	1	1	1	1
838	MF 20A0 131	W453513	油 受 ケ 台	Oil bottle bracket	1	1	1	1	1	1	1	1	1	1	1	1	1	1	1	1	1	1
839	M9 1571 045		ナ ッ ト 6	Nut	1	1	1	1	1	1	1	1	1	1	1	1	1	1	1	1	1	1
840	M9 0601 053		バ ネ 座 金 6	Spring washer	1	1	1	1	1	1	1	1	1	1	1	1	1	1	1	1	1	1
841	M9 0702 050	W502735	座 金 6	washer	1	1	1	1	1	1	1	1	1	1	1	1	1	1	1	1	1	1
842	M9 1551 045		ボ ル ト 6×12	Bolt	1	1	1	1	1	1	1	1	1	1	1	1	1	1	1	1	1	1
843	MF 10E0 149	W219663	油 缶	Oil can	1	1	1	1	1	1	1	1	1	1	1	1	1	1	1	1	1	1
917		W338200G01	ベルトカバー(組)	Belt cover complete						(特 注)		(Option)										

From the library of: Diamond Needle, Ltd.



未来を開発する  
三菱電機

Supponion

From the library of: Diamond Needle Corp